



58 G/64 Gbaud Multichannel PAM4 BERT

PAM4 PPG MU196020A

PAM4 ED MU196040B

Signal Quality Analyzer-R

MP1900A Series



Outline of MP1900A Series PAM4 BERT

- Supports bit error rate measurements optimized for high-speed 400 GbE and next-generation 800 GbE interfaces
- High-quality data output waveforms up to 64 Gbaud and high input sensitivity performance provide strong support for testing PAM4 device designs
- All-in-one Jitter Addition, Clock Recovery, Emphasis, NRZ/PAM3/PAM4 Pattern Editing, SER, FEC functions, etc.
- Easily configured, high-reproducibility PAM4 measurement solution

MP1900A PAM4 Target Applications

200/400/800 GbE, CEI-56G/112G, InfiniBand HDR, 64G Fibre Channel

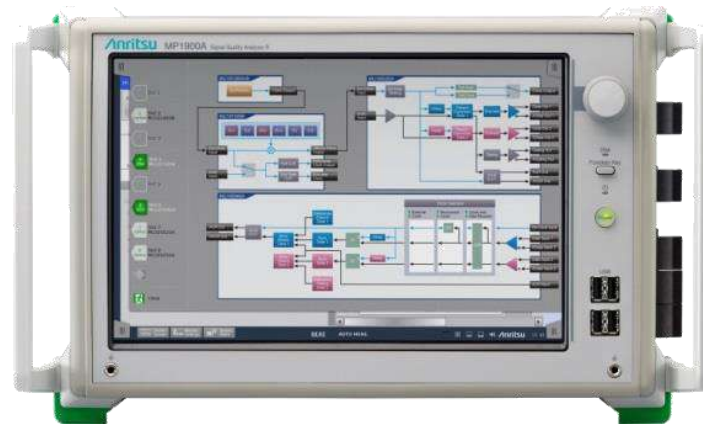

MP1900A PAM4 BERT Features

- All-in-one, high-reproducibility, easily configured test solution
- High-quality waveforms for more accurate measurement
- Easy, low-cost, future-proof expandability supporting high bit rates and multichannels

PAM4 One Box Test Solution

Emphasis 4Tap, 20 dB

Built-in Clock Recovery, Equalizer



Jitter/Noise Addition

Jitter Tolerance Test

FEC Symbol Error Analysis

Highest Level Waveform Quality

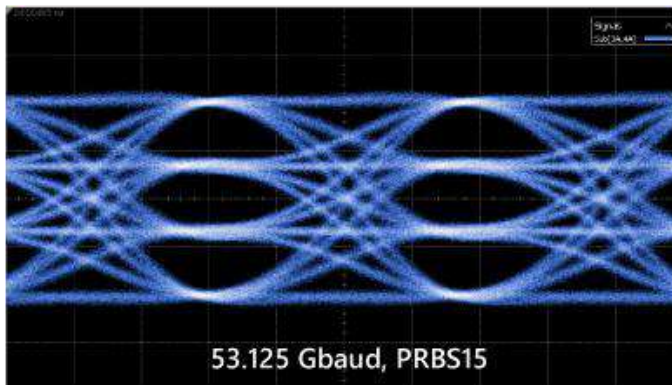

Next-Generation Terabit

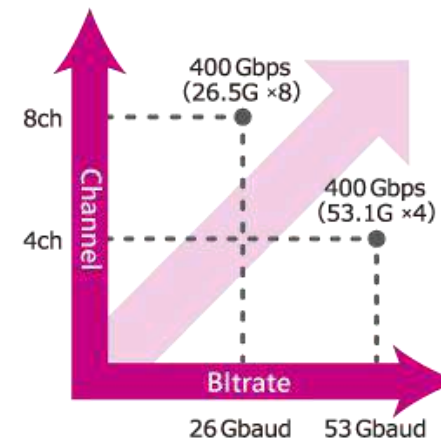

PAM4 All-in-One BERT Solution

Easy-to-use and configure all-in-one solution with high reproducibility, helping cut test times

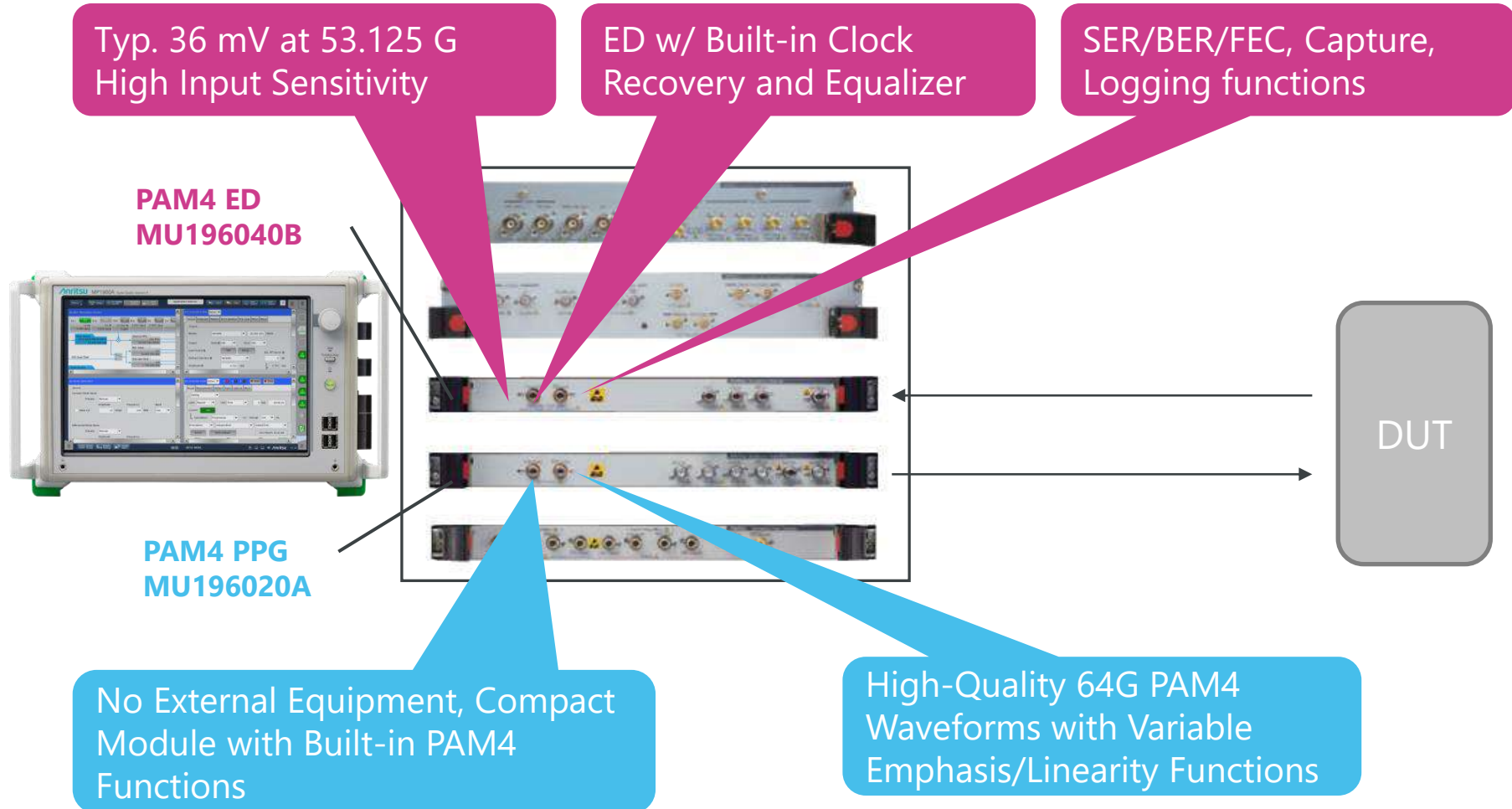

High-Quality Waveform PAM4 PPG MU196020A

Best-in-class waveform quality with low Intrinsic Jitter (typ. 170 fs (rms)) and fast Tr/Tf (typ. 8.5 ps) for more accurate evaluation of actual DUT performance

64.2 Gbaud

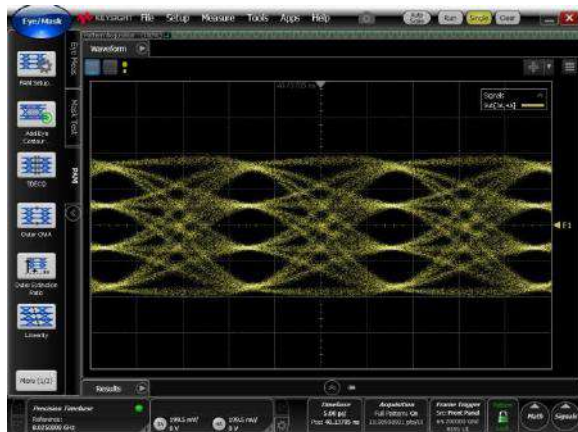

53.125 Gbaud

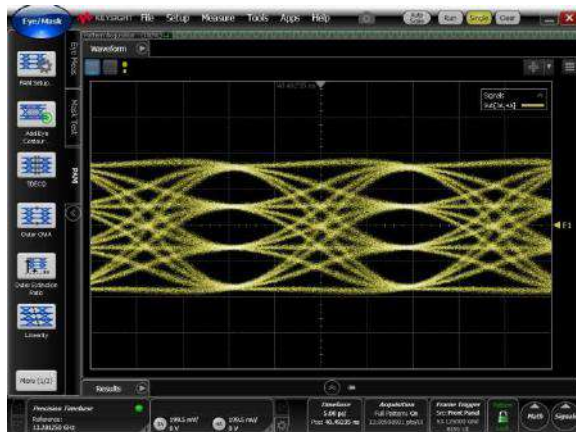

26.5625 Gbaud

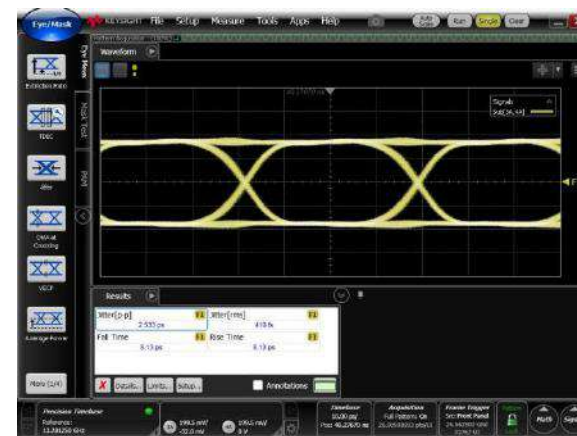
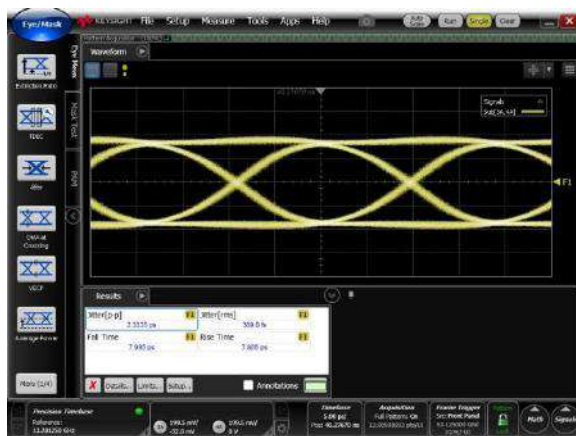
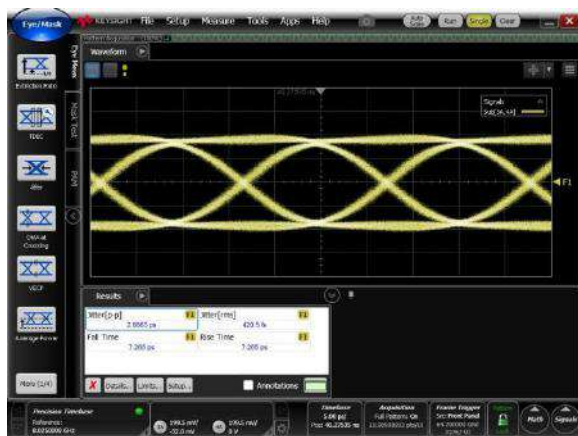
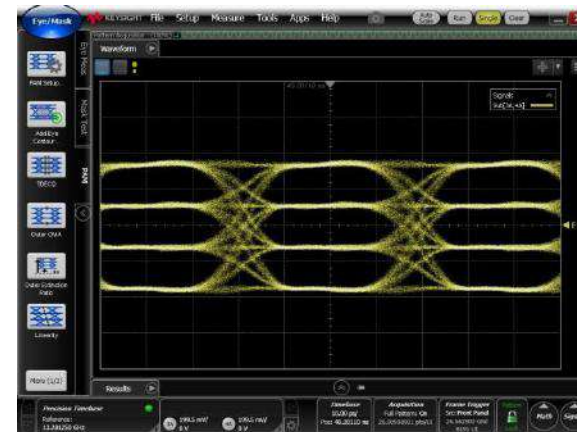

Differential 1.4 Vp-p, PRBS13Q pattern, J1789A 40-cm cable + 70 GHz Scope

116 Gbit/s PAM4 Best Level High-Sensitivity Input Performance

High sensitivity input of 36 mV (typical at 53.125 Gbaud) simplifies previously difficult PAM4 error troubleshooting measurements.

Error-Free at 53.125 Gbaud
Best level PAM4 sensitivity

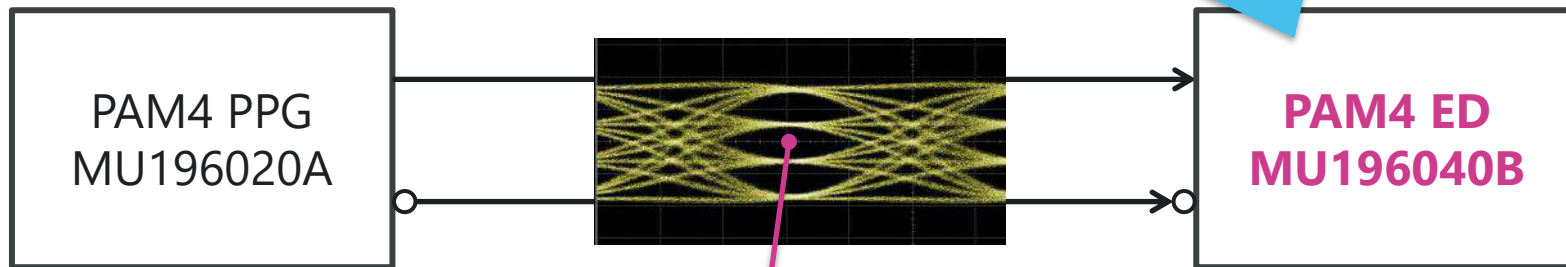

Typ. 36 mV EH/ Eye

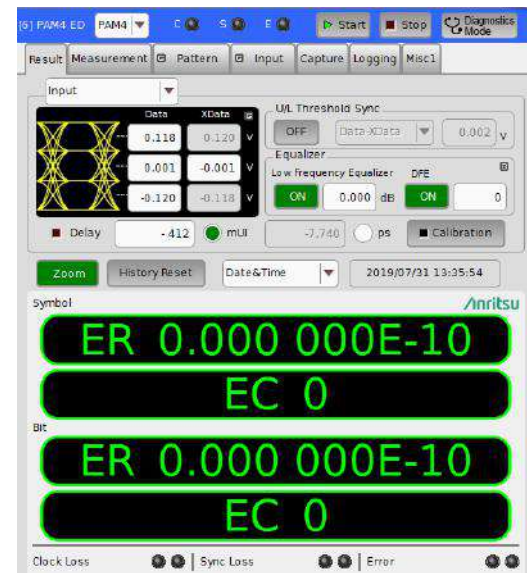

Multichannel Support and Expandability (1/2)

One MP1900A PPG supports up to 4ch for 400 GbE (53 Gbaud x 4 Lanes), and faster evaluations, helping cut future support upgrade costs.

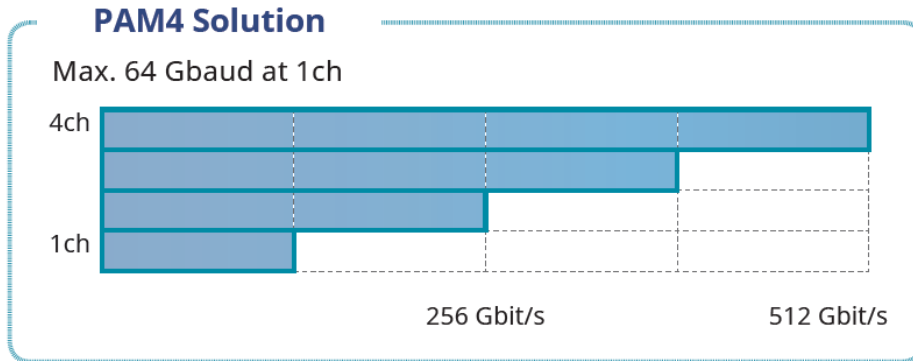

• Channel Synchronization

One MP1900A unit supports synchronous output for up to 4ch; two units support up to 8ch.

*Future support for 8ch



• 2ch Combination (NRZ)

Supports shift to "a1b1 a2b2 . . ." pattern

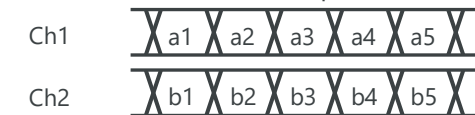

• 4-Lane DUT (Driver + E/O) Measurement Example

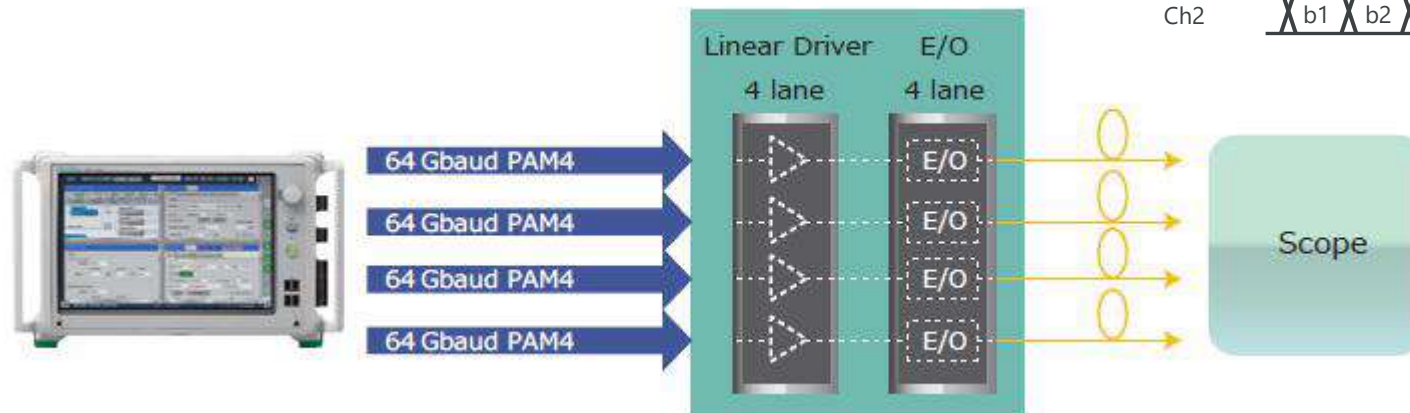

Multichannel Support and Expandability (2/2)

Expanded support for 800G using 8ch synchronization function
(4ch x 53.125 Gbaud PAM4 x two MP1900A units)

Supports QSFP-DD transceiver FEC evaluation using 8-lane FEC Pattern
Generation function

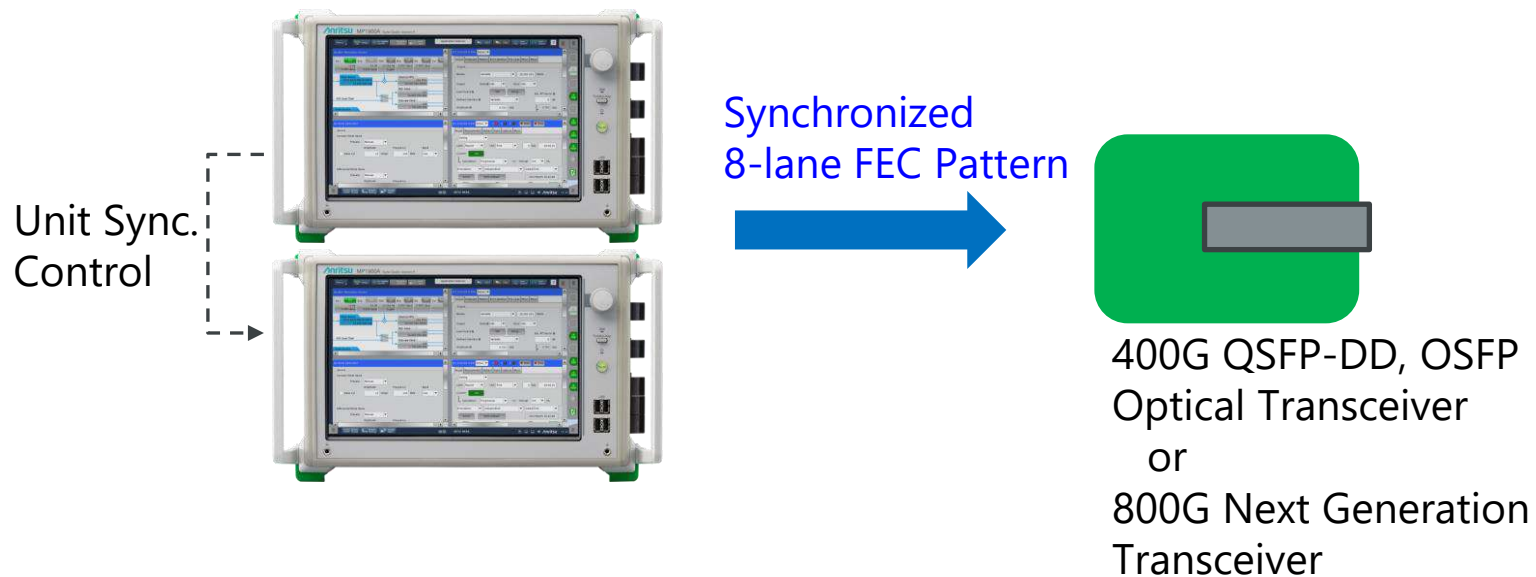

Jitter Tolerance Measurement Function

Supports PAM4 Jitter Tolerance test using just one unit. A measurement system to help cut measurement time is configured easily by combining the Jitter/Noise Addition function, built-in Clock Recovery function, and Jitter Tolerance MX183000A-PL001 software.

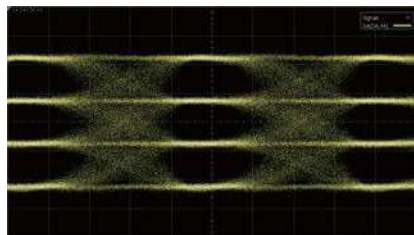
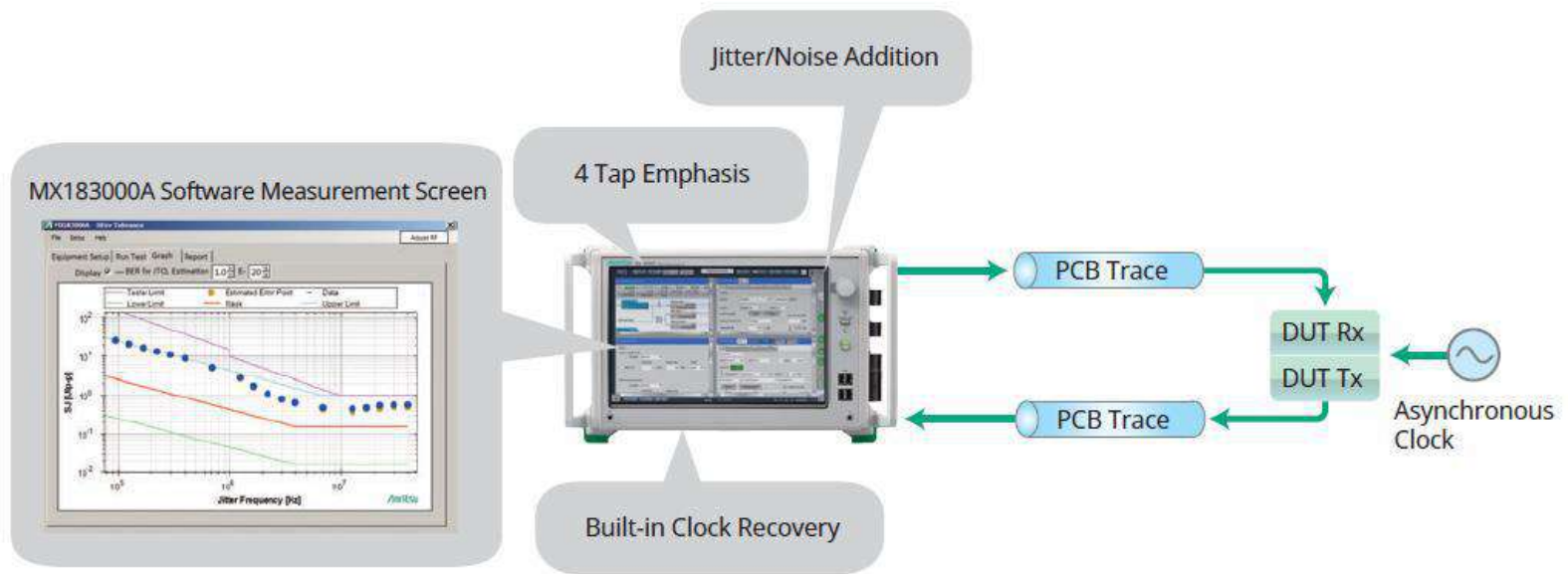

Sine-Wave Jitter (SJ)

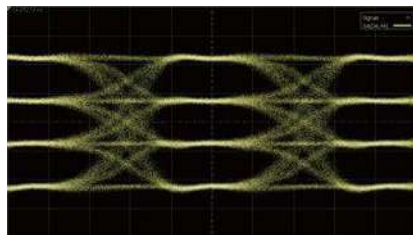

Random Jitter (RJ)

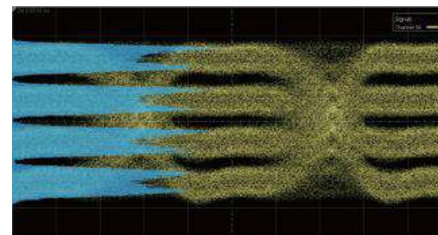

CM/DM Noise

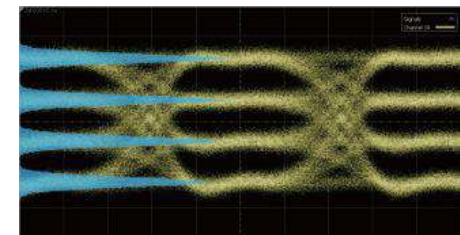

White Noise

Real-time FEC Symbol Error and FEC Standard Jitter Tolerance Measurement Functions

Uncorrectable Codeword and FEC Symbol Errors can be measured and displayed on one screen in real-time simultaneously with bit error measurements. Measurement of jitter tolerance and FEC Symbol Error per codeword distribution based on correctable/uncorrectable FEC is supported (MU196040B-042). Both bit error and FEC Symbol Errors are measured at high speed.

Real-time FEC Symbol Error Measurement

| | Uncorr. Codeword | FEC Symbol | Bit |
|-----|------------------|---------------|---------------|
| ER: | 5.120 000E-08 | 3.504 500E-03 | 1.804 400E-04 |
| EC | 1 | 1.861 800E+07 | 1.517 100E+07 |
| %ER | 90.000 000 | 0.000 000 | |
| EI | 1 | 10 | |

Frequency(kHz) 53 124 999 Clock Count 5.312 400E+10

**MP1900A
PAM4 BERT**

PAM4 Test Signal with Jitter → Test Board
← PHY IC

FEC Symbol Error Distribution

RS-FEC Error Distribution

CW Frequency

Codeword with N FEC Symbol Errors

Gating (45%)

FEC based Jitter Tolerance test (MX183000A-PL001)

S/N [dB]

Jitter Frequency [ps]

Jitter Tolerance Measurement using DUT BER Counter

When the DUT has a built-in bit error counter, combination with the MP1900A PPG makes it easy to configure a highly cost-effective Jitter Tolerance measurement environment.

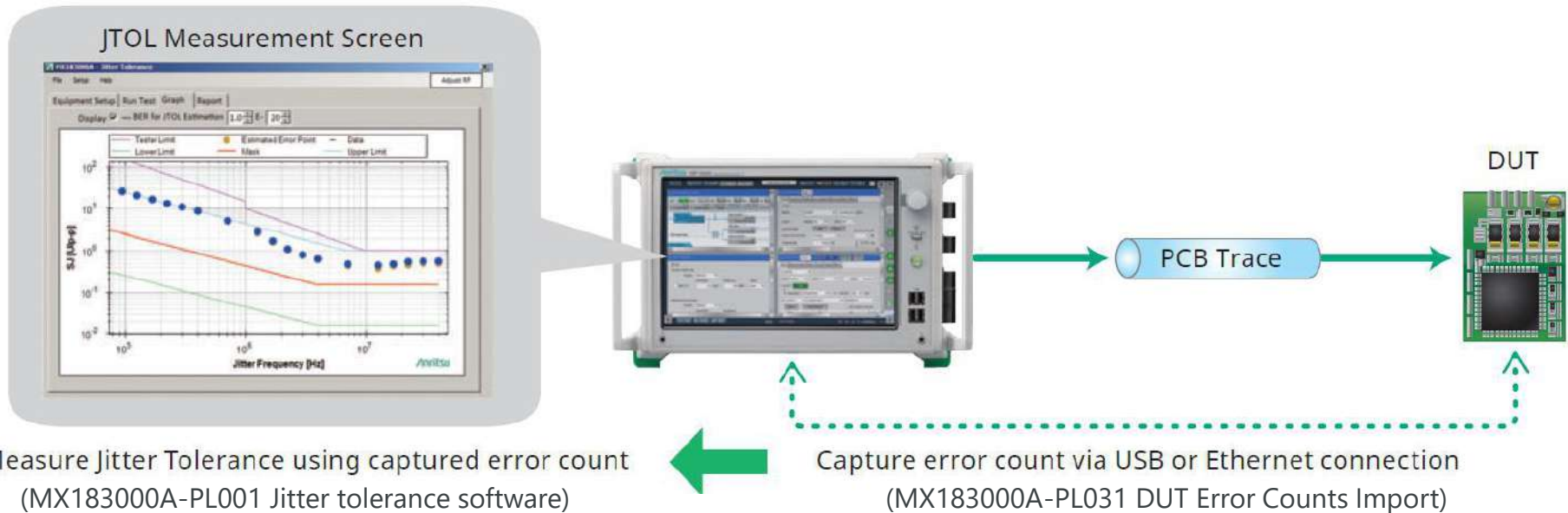

Multilane FEC Evaluation

FEC can be evaluated by combining FEC pattern generation with error insertion, and reading the DUT bit error count.

Evaluating Optical FEC Signal Transmission

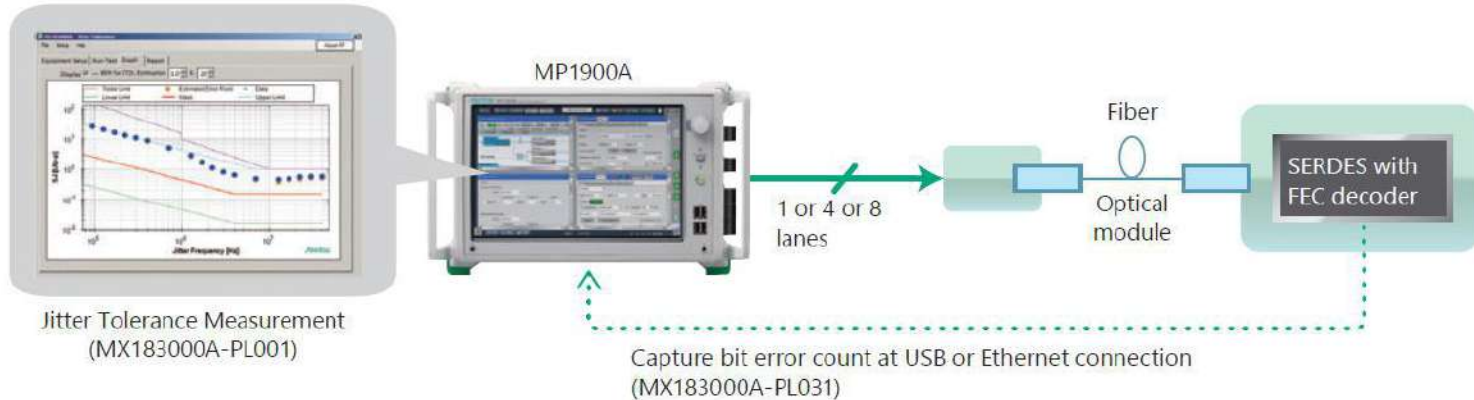

Evaluating Electrical FEC Signal Transmission

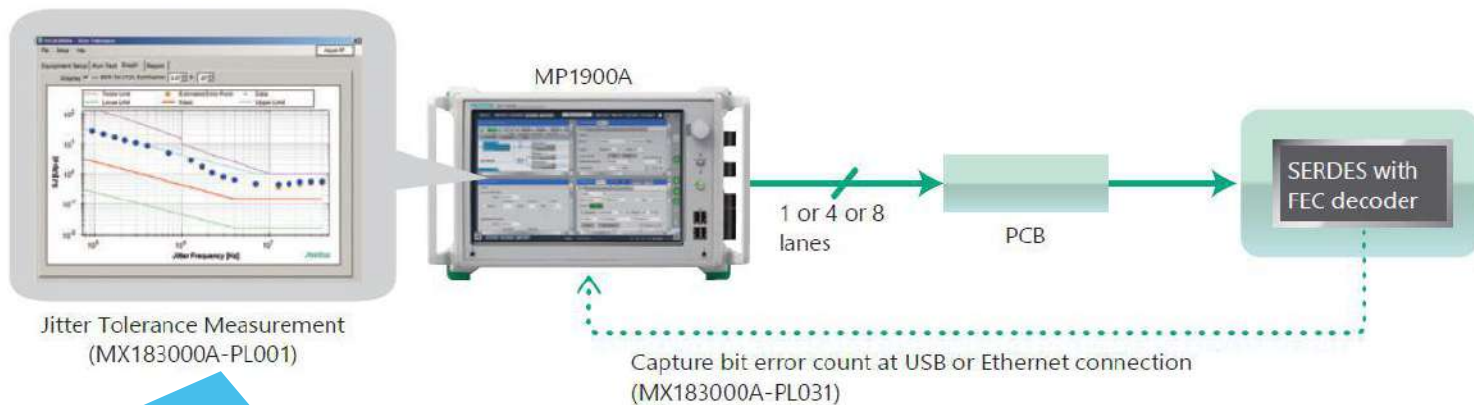

Evaluate Jitter Tolerance, etc., using captured error count

PAM4 PPG MU196020A



- Baud-rate: 2.4 Gbaud to 32.1/58.2/64.2 Gbaud
- Output amplitude: 0.14 Vp-p to 1.6 Vp-p (Differential)
- Emphasis: 4Tap, ± 20 dB (1 post/2 pre-cursor), ISI/Channel Emulator
- Intrinsic jitter(rms): 170 fs (typ., NRZ)
- Tr/Tf (20-80%): 8.5 ps (typ., NRZ)
- Multichannel synchronization
- FEC pattern generation

PAM4 ED MU196040B



- Baud-rate: 2.4 Gbaud to 32.1/58.2 Gbaud PAM4 and 64.2 Gbaud NRZ
- Input amplitude (max.): 1.0 Vp-p (NRZ, PAM4)
- Input sensitivity(Eye Height) : 23 mV (typ., 26.5625 Gbaud), 36 mV (typ., 53.125 Gbaud)
- Built-in Clock Recovery: 2.4 G to 29 Gbaud or 32.1 Gbaud/ 51 G to 58.2 Gbaud extension
- Analog bandwidth: >40 GHz (nominal)
- Built-in Equalizer: Low Frequency Equalizer(2 dB)+DFE(1.4 dB)
- SER measurement, logic error analysis using Diagnostics Mode, Capture , Logging function
- Real-time FEC Symbol Error measurement, FEC based Jitter Tolerance Test function



PAM4 PPG Functions and Performance

PAM4/NRZ Data Output

Supports next-generation applications over 50 Gbaud, such as 400/800 GbE, CEI-112G, etc.

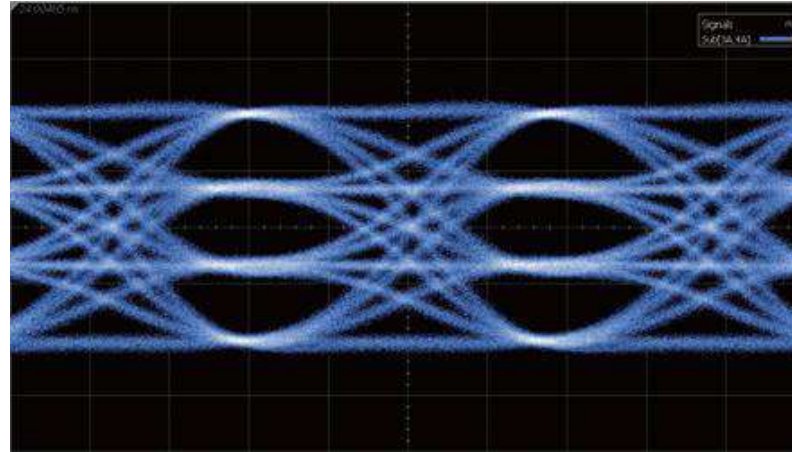

53.125 Gbaud PAM4

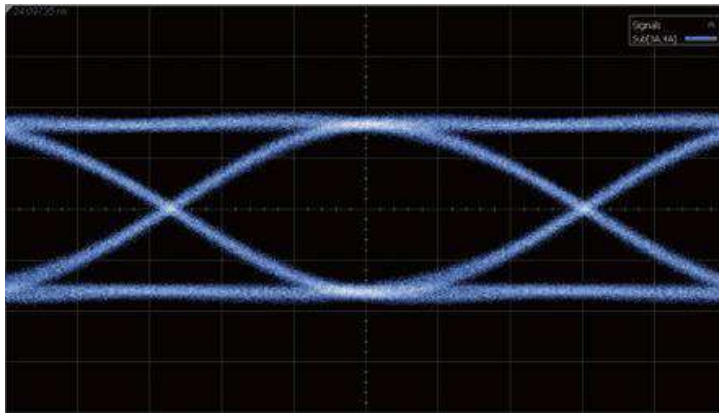

58 Gbaud NRZ

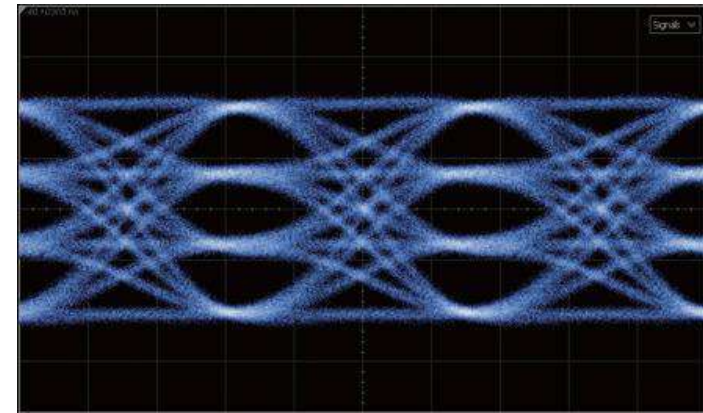

58 Gbaud PAM4

Typical Output Waveform (J1789A 40-cm Cable, 1400-mV Differential, PRBS15)

Easy PAM4 Level Control

Control Baud Rate, Level, Offset, Half Period Jitter, and Delay from one screen

The screenshot shows the PAM4 PPG control interface. At the top, it displays "[7] PAM4 PPG" and "PAM4" with a dropdown menu. Below this are tabs for "Output", "Emphasis", "Pattern", "Error Addition", "Misc1", and "Misc2". The "Output" tab is active, showing settings for Baud Rate (Variable, 64.200 000 GBaud), Output (Data ON, Clock ON), and Level Guard (OFF). A "Total Amplitude" control is set to 0.700 Vpp. The waveform display shows four levels: Level3 Voltage (0.350 V), Level2 Voltage (0.117 V), Offset (0.000 V), and Level1 Voltage (-0.117 V). The waveform is a complex, multi-colored signal. Below the waveform, there are controls for Half Period Jitter (0), Cable for Data Output (J1789A 0.4m Cable (Recommend)), Delay (0 mUI), and Jitter Input (OFF).

- PAM4 Total Amplitude setting
- Independent PAM4 3Eye Amplitude control with voltage and % values
- Easy return to equal level using [Even] button

Level Control Reference Waveform

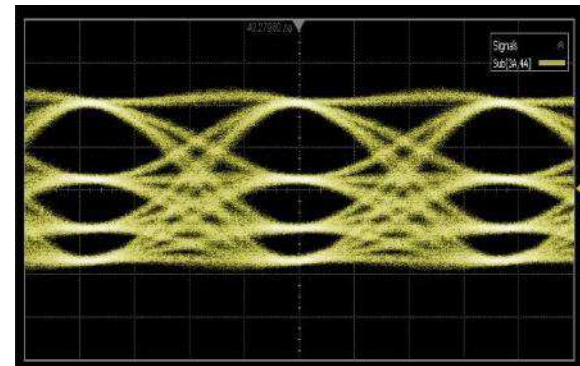

Linearity and Emphasis Controls

Supports TOSA device evaluations and stressed input tests using various channel insertion losses

MU196020A
PAM4 PPG

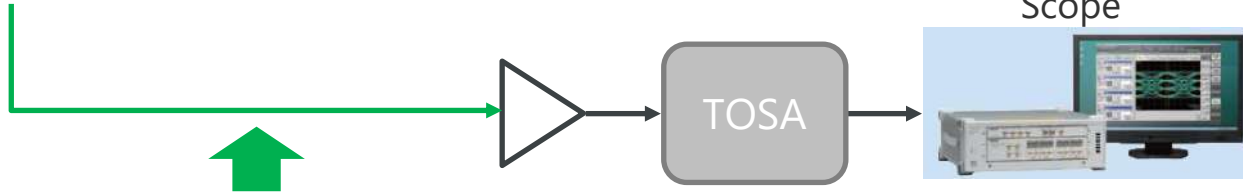

53G, Linearity control

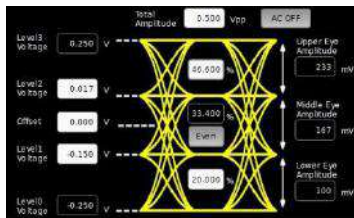
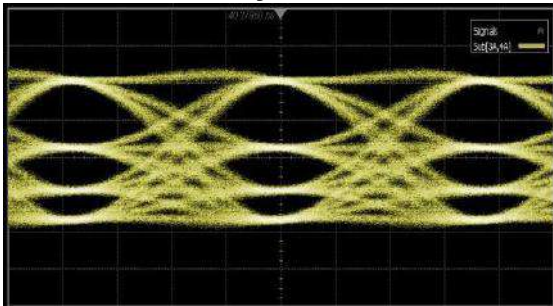

53G, Post1 Emphasis control

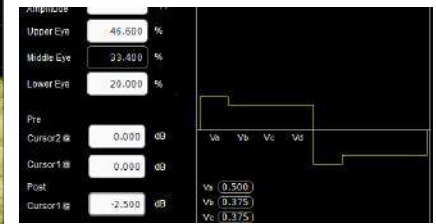
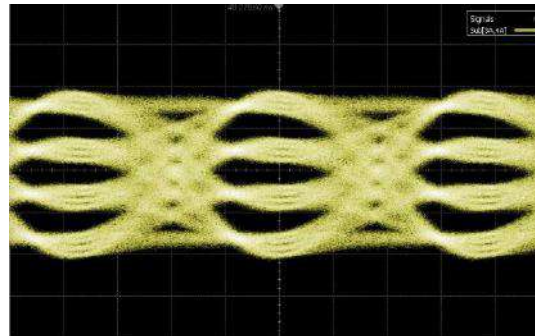

53G, Pre1 Emphasis control

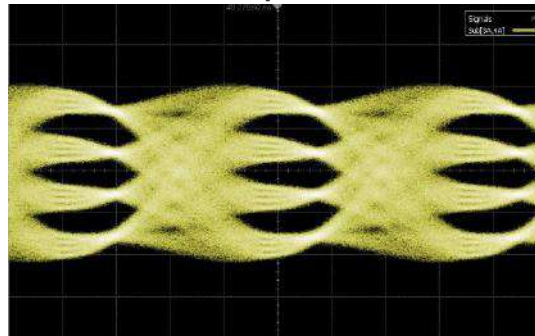

Shorter development period by eliminating need for multiple test PC boards with simple and high-reproducibility design tests of high-speed device channel loss dependency

- **Manual Setting:** Correct signal for target Eye Height/Width using 10Tap Emphasis function
- **Channel Emulator:** Emulate S2P and S4P loss insertion, and perform Emphasis compensation
- **ISI:** Emulate ISI using CEI-28G/25G Nyquist frequency loss setting

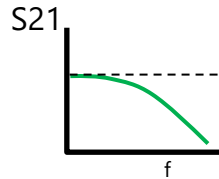
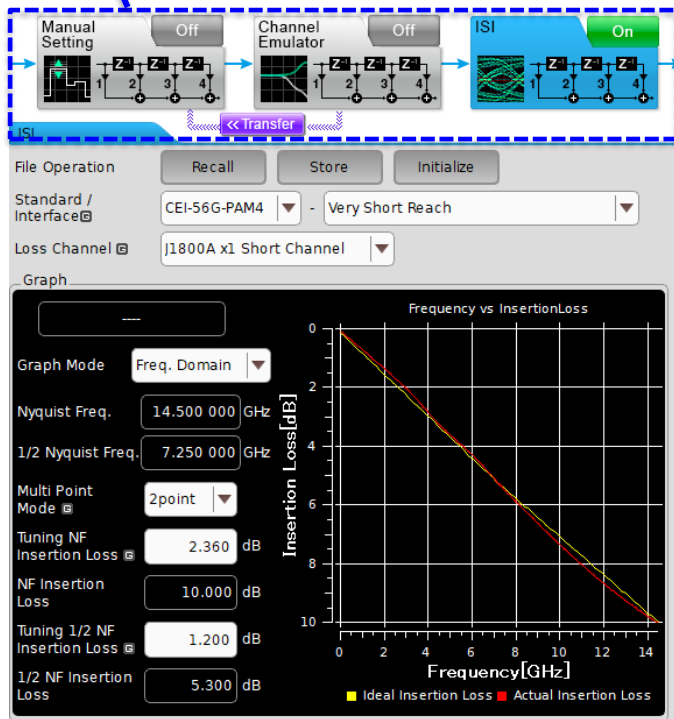

Emulates Channel Loss
or
Generates Loss
Calibration Signal
(ISI option)

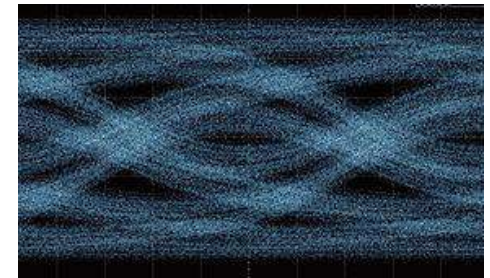

NRZ CEI-28G 14-dB Loss

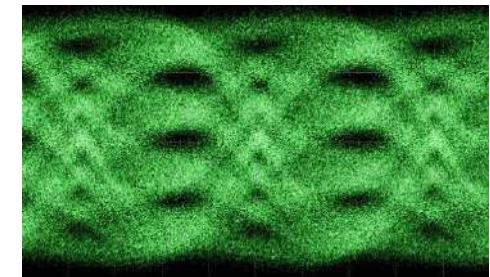

PAM4 26.6G 4-dB Loss

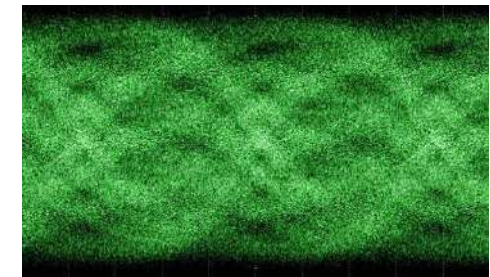

PAM4 26.6G 6-dB Loss

Typical ISI Function Waveforms

PAM4 Test Patterns (1/2)

Supports PAM4 test patterns specified by 200 and 400 GbE standards

| Supported Test Patterns | |
|-------------------------|--|
| CEI | QPRBS13-CEI, QPRBS31-CEI |
| IEEE | IEEE802.3bs/cd: PRBS13Q, PRBS31Q, SSPRQ, Square Wave IEEE802.3bj: QPRBS13, JP03A, JP03B, Transmitter Linearity |
| RS-FEC | RS-FEC Scrambled Idle 50G 1 Lane (26.5625 Gbaud, 50GBASE-KR/CR/SR/FR/LR) RS-FEC Scrambled Idle 100G 1 Lane (53.125 Gbaud, 100GBASE-DR/KR1/CR1) RS-FEC-Int Scrambled Idle 100G 1 Lane (53.125 Gbaud, 100GBASE-P) RS-FEC Scrambled Idle 100G 2 Lanes 26.5625 Gbaud, 100GBASE-KR2/CR2/SR2) RS-FEC Scrambled Idle 200G 4 Lanes (26.5625 Gbaud, 200GBASE-SR4/DR4/FR4/LR4) RS-FEC Scrambled Idle 200G 2 Lanes (53.125 Gbaud, 200GBASE-KR2/CR2) RS-FEC Scrambled Idle 400G 4 Lanes (53.125 Gbaud, 400GBASE-DR4/KR4/CR4) RS-FEC Scrambled Idle 400G 8 Lanes (26.5625 Gbaud, 400GBASE-FR8/LR8) |
| InfiniBand | PRBS13Q (InfiniBand), PRBS23Q, PRBS31Q(InfiniBand) |
| Fibre Channel | PRBS31Q (Fibre Channel) |
| General Purpose | PRBS7, 9, 10, 11, 13, 15, 20, 23, 31, Data (User defined) 4 to 256 Msymbol |

Edit Data pattern using PAM4 symbol 0, 1, 2, and 3 values.

The screenshot shows the 'Pattern Editor' interface. At the top, there is a 'File' button and 'Cursor Addr 7'. Below this, a grid of data is displayed with columns labeled +0, +4, +8, +12, +16, +20, +24, +28, and +32. The first three columns (+0, +4, +8) contain the values 3, 2, 1, 0, 0, 1, 2, 3. A dashed blue box highlights the values 3, 2, 1, 0, 0, 1, 2, 3. To the right of the grid, there are several input fields: 'Number of Block', 'Row Length', 'Data Length' (set to 16), 'Number of Row', and 'Edit Block'.

PAM4 Test Patterns (2/2)

- BER measurement for different pattern generation methods depending on DSPs
- Efficient detection of pattern generation circuit differences as well as logic errors, such as inverted logic and bit skew

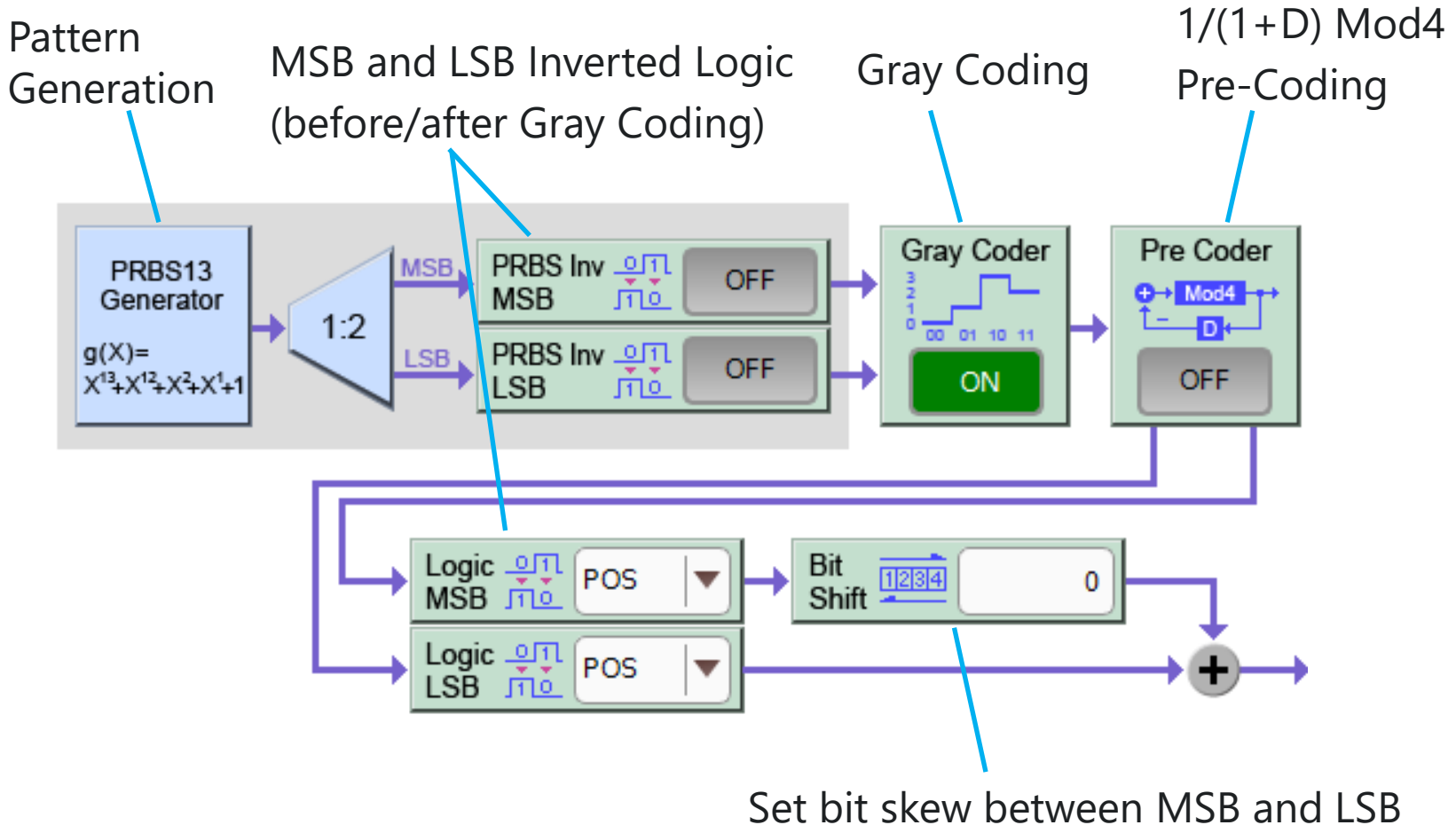

PAM4 Error Insertion Function

With PAM4, not only do errors occur at single level changes, there are also cases where double level changes occur due to MSB errors.

Using the [Error Addition] tab to insert errors in each of these cases helps confirm communications and inspection of error results.

• LSB Error Insertion

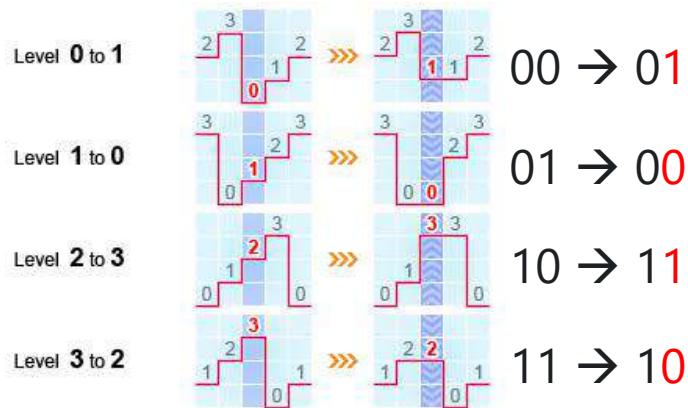

• MSB Error Insertion

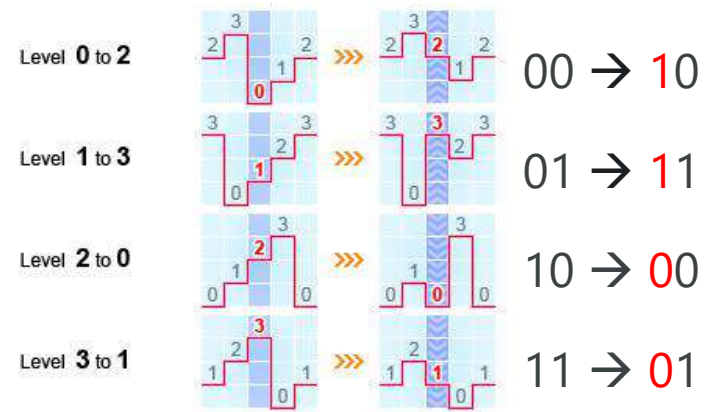

Adjusts Emphasis to automatically correct loss of 80-cm cable connecting separate DUT

Cable for data output setting: J1789A 0.4 m

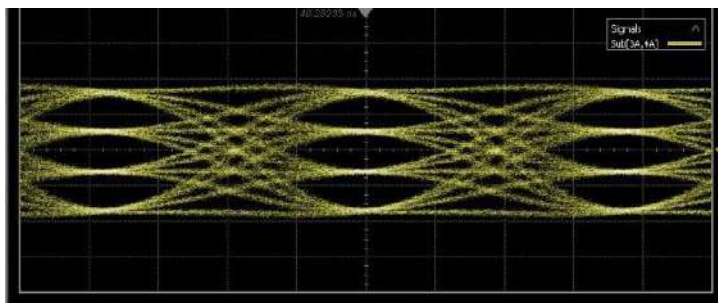

Using
40-cm cable
@53G

← J1789A 40-cm cable best for evaluating this waveform

↘ Closed Eye opening with long cable (ex. 80-cm cable)

↓ Can automatically calibrate settings for effect of 80-cm cable

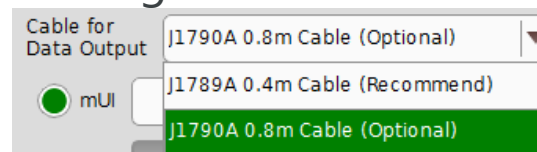

Select J1790A
cable setting

Cable for data output setting: J1789A 0.4 m

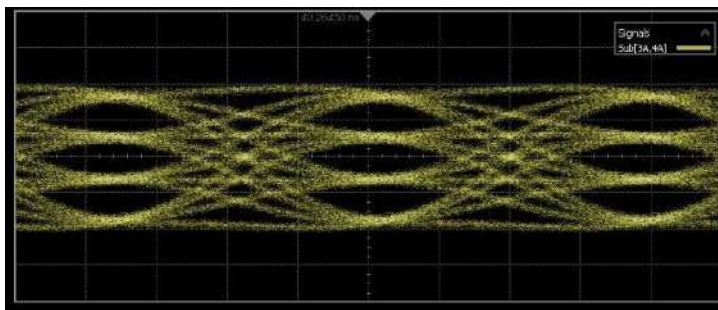

Using
80-cm cable
@53G

Cable for data output setting: J1790A 0.8 m

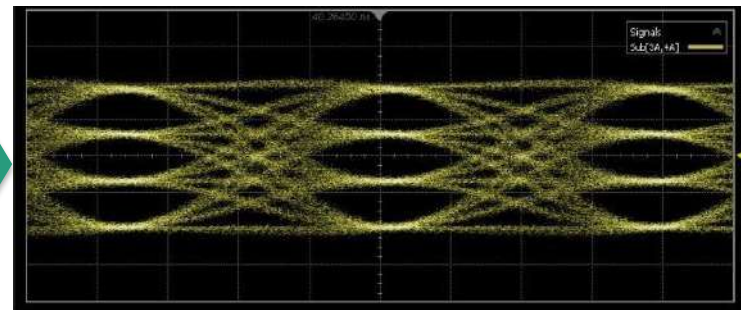



PAM4 ED Functions and Performance

Outline of 116-Gbit/s PAM4 Error Detector for 400 GbE/800 GbE

- **High-performance BERT for 116-Gbit/s PAM4 error-free measurement**
Simplify previously difficult PAM4 error troubleshooting
- **Industry-best high input sensitivity of 36 mV EH@53.125 Gbaud**
Support more accurate evaluations up to 116-Gbit/s PAM4.
- **All-in-one 58-Gbaud PAM4 receiver test solution with built-in Clock Recovery and Equalizer functions**
Support faster testing and debugging with easy measurement system configuration
- Wideband operation: 2.4 Gbaud to 64.2 Gbaud for NRZ
2.4 Gbaud to 58.2 Gbaud for PAM4
- Support CEI-112G-VSR Stressed Receiver Input Test
- Built-in 58-Gbaud PAM4 Clock Recovery
- PAM4 symbol Capture function
- Multichannel measurement (up to 4ch/unit)
- Real-time FEC Symbol Error measurement, FEC based Jitter Tolerance test

Target Applications: 100/200/400/800 GbE, CEI-112G-VSR

All-in-One BERT w/ PAM4 Built-in Clock Recovery & Equalizer

Connections with external equipment and components are eliminated. PAM4 Jitter Tolerance measurements are simplified by the easy system configuration.

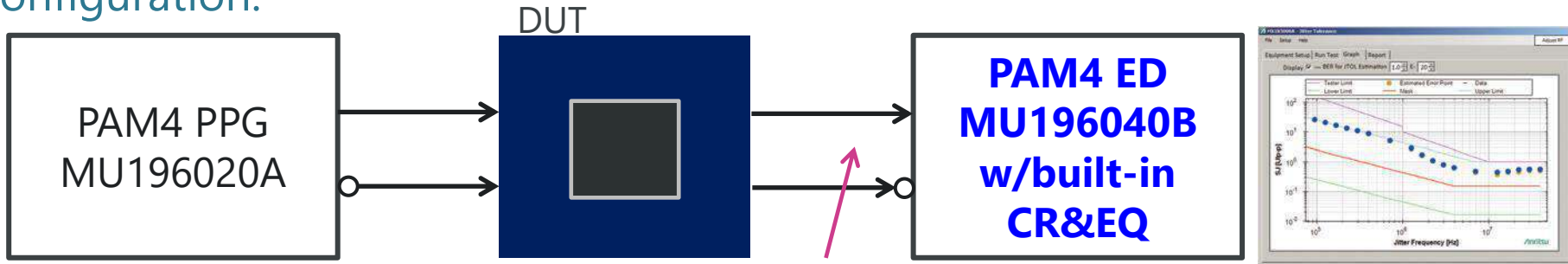

- Jitter
- ISI Control

Support BER measurement of closed-Eye signal with stress

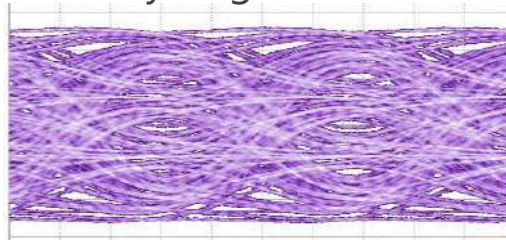

Support PAM4 Jitter Tolerance test

• **Built-in Clock Recovery** to re-time DUT signal for 58-Gbaud PAM4 JTOL testing

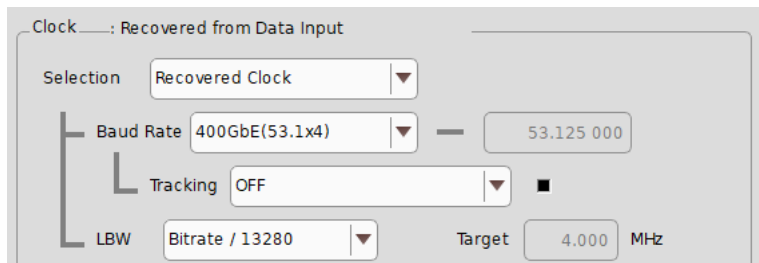

• **Equalizer function** to open Eye of VSR stressed signal for measuring BER

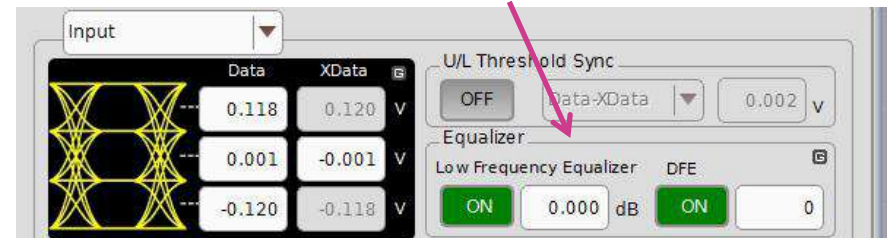

CEI-112G-VSR Stressed Input Test Support

The true DUT low-error-rate Rx performance can be tested with added stress.

CEI-112G-VSR Rx input specification

| Item | Spec. (112G-VSR-PAM4) |
|--------------|-----------------------|
| Baud Rate | 36 to 58 Gbaud |
| Channel Loss | 12 dB at 26.5625 GHz |
| EH6 | > 37 mV |
| EW6 | > 0.2 UI (> 3.76 ps) |
| Target BER | < E-6 |



Using MU196020A PPG output and ISI board as calibrated signal (oscilloscope CTLE 2.5 dB setting) supporting Rx Input standard performance

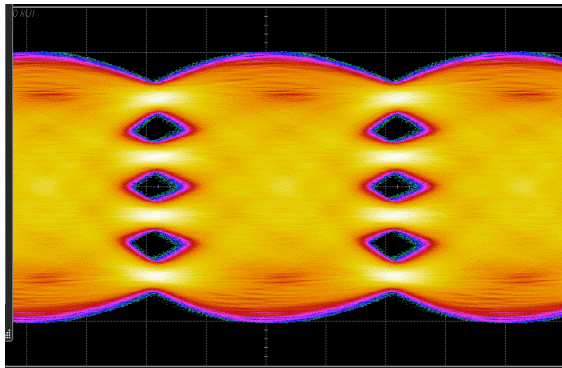

Higher sensitivity performance (E-8 or lower) than receiver model defined by CEI VSR standard (E-6)

Built-in Equalizer

Combination of built-in Equalizer function and high input sensitivity performance supports higher accuracy measurements.

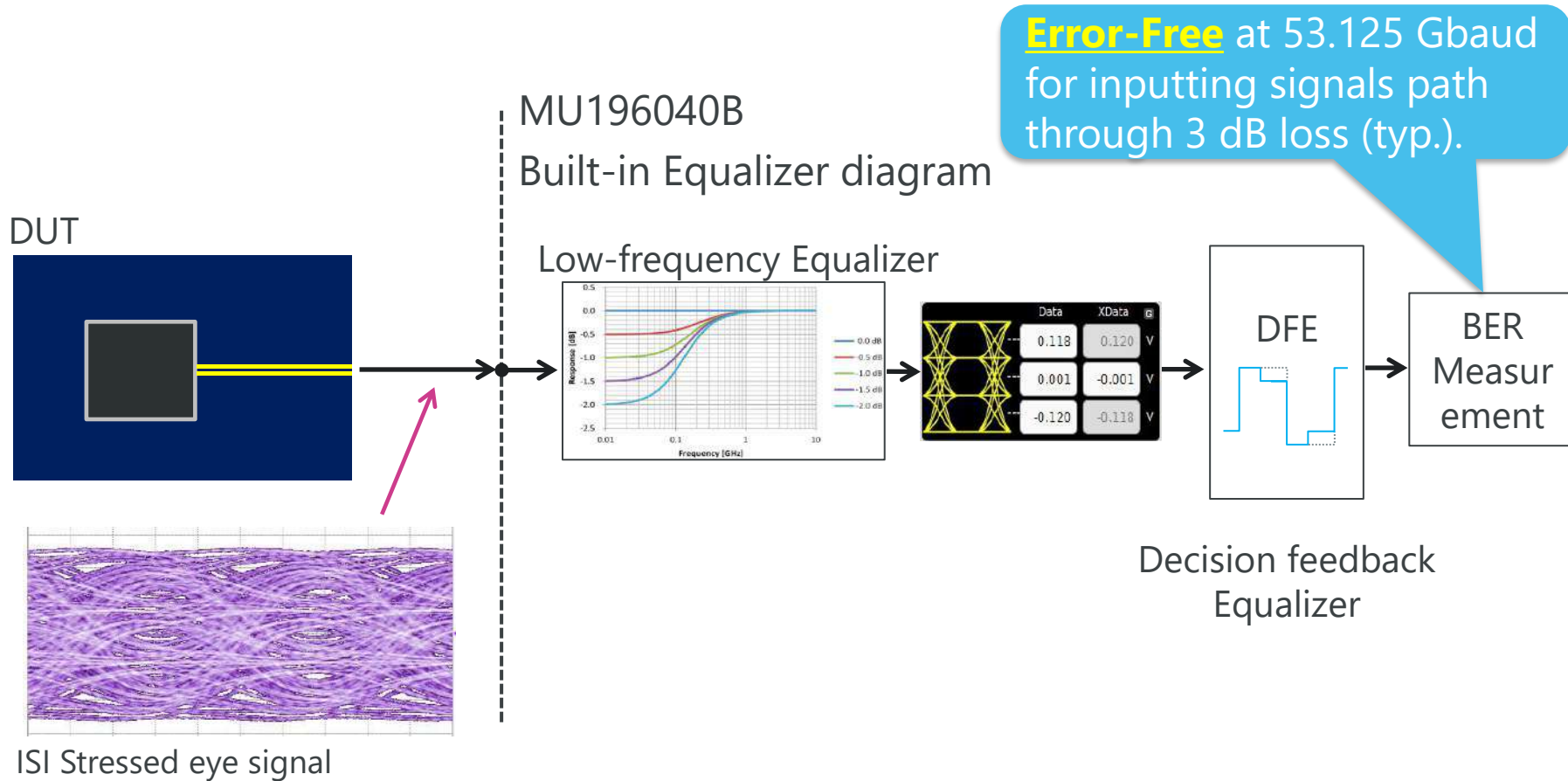

Real-time FEC Symbol Error Measurement

Uncorrectable Codeword, FEC Symbol Error, and Bit Error measurement results on one screen

MSB/LSB Errors and Codeword Counts and Rate for each Symbol Error Count on Details Screen

MU196040B PAM4 ED Result Screen

The screenshot shows the main result screen with the following data:

| | Uncorr. Codeword | FEC Symbol | Bit |
|------|------------------|---------------|---------------|
| ER | 5.120 000E-08 | 3.504 500E-03 | 1.804 400E-04 |
| EC | 1 | 1.861 800E+07 | 1.917 100E+07 |
| %EFL | 90.000 000 | 0.000 000 | |
| EI | 1 | 10 | |

Other parameters shown include: Frequency(kHz) 53 124 999, Clock Count 5.312 400E+10, Total Codeword Count 1.953 100E+07, and various error indicators for Clock Loss, Sync Loss, PAM4 Symbol/Bit Error, FEC Symbol Error(MSB/LSB), and Uncorr. Codeword Error.



The screenshot shows the 'Details(Slot6)' window with the following data:

| | | Uncorr. Codeword | FEC Symbol | Bit | | |
|-----------|----|------------------|---------------|---------------|---------------|---------------|
| | | | | Total | INS | OMI |
| MSB | ER | | 6.934 500E-04 | 3.503 500E-05 | 6.975 900E-05 | 3.121 300E-07 |
| | EC | | 1 841 995 | 1 861 282 | 1 852 991 | 8 291 |
| LSB | ER | | 6.315 700E-03 | 3.258 400E-04 | 3.116 500E-04 | 3.400 300E-04 |
| | EC | | 1.677 600E+07 | 1.731 000E+07 | 8 278 443 | 9 032 132 |
| MSB + LSB | ER | 5.120 000E-08 | 3.504 500E-03 | 1.804 400E-04 | 1.907 000E-04 | 1.701 700E-04 |
| | EC | 1 | 1.861 800E+07 | 1.917 100E+07 | 1.013 100E+07 | 9 040 423 |

| FEC Symbol Error Count | Codeword Rate | Codeword Count |
|------------------------|---------------|----------------|
| 0 | 4.330 700E-01 | 8 458 502 |
| 1 | 3.167 900E-01 | 6 187 331 |
| 2 | 1.582 500E-01 | 3 090 827 |
| 3 | 6.127 600E-02 | 1 196 814 |
| 4 | 2.105 900E-02 | 411 311 |
| 5 | 6.644 200E-03 | 129 771 |
| 6 | 2.030 000E-03 | 39 649 |
| 7 | 6.084 000E-04 | 11 883 |
| 8 | 1.843 700E-04 | 3 601 |
| 9 | 5.631 900E-05 | 1 100 |
| 10 | 1.607 600E-05 | 314 |
| 11 | 4.352 000E-06 | 85 |
| 12 | 2.048 000E-06 | 40 |
| 13 | 6.144 000E-07 | 12 |
| 14 | 3.584 000E-07 | 7 |
| 15 | 1.024 000E-07 | 2 |
| Uncorr.Codeword | 5.120 000E-08 | 1 |

Additional parameters at the bottom include: Clock Loss 0, Sync Loss 0, PAM4 Symbol/Bit Error, and FEC Symbol Error(MSB/LSB) indicators.

Jitter Tolerance Measurements Based on FEC Symbol Errors

One-button jitter tolerance measurement is supported based on whether or not error correction using FEC is possible.

MP1900A PAM4 BERT



PAM4 Test Signal with Jitter

Test Board



Jitter Frequency and Test Mask Settings

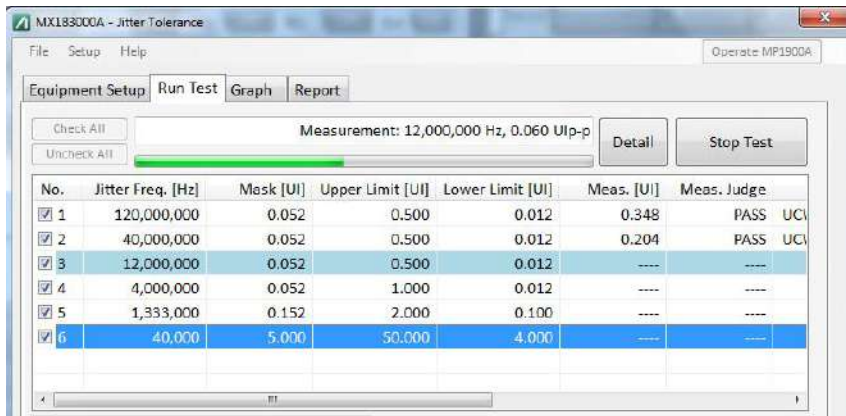

Correctable Error Jitter Tolerance Test Result

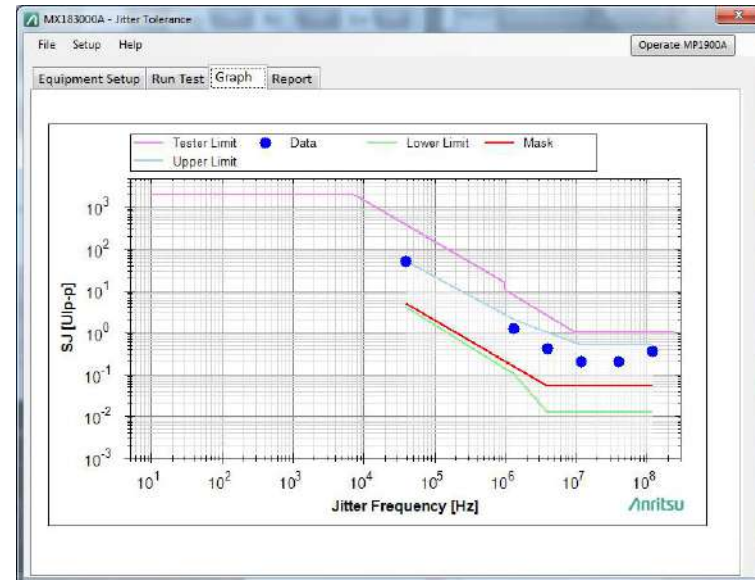

Test Criterion Setting, Bit Error or Uncorrectable Codeword

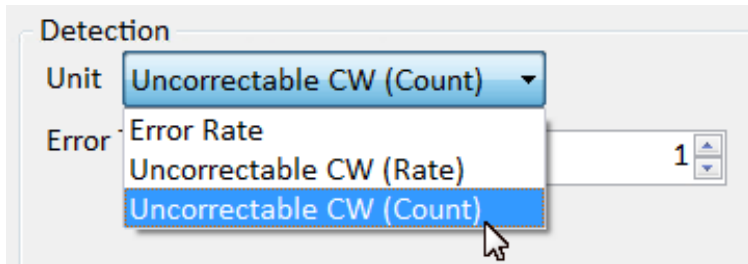

FEC Symbol Error Distribution in Real-time

Supports FEC Symbol Error Distribution function.
Monitor changes in input signal conditions, such as jitter stress, in real-time.

Error Free

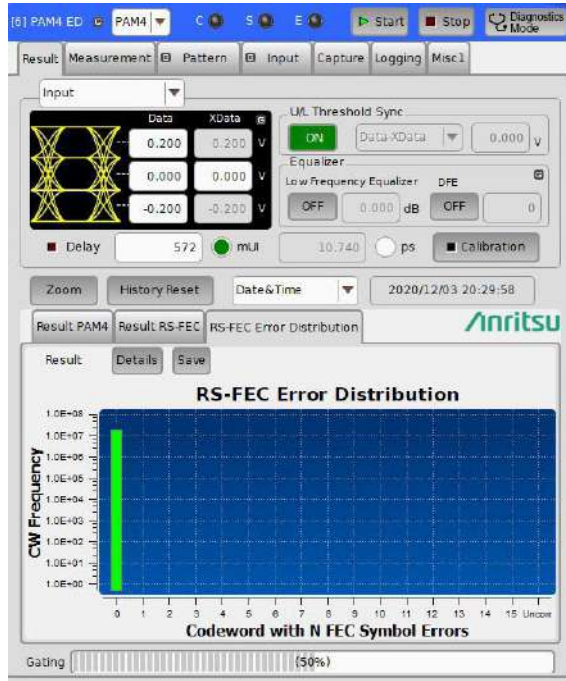

Correctable Errors

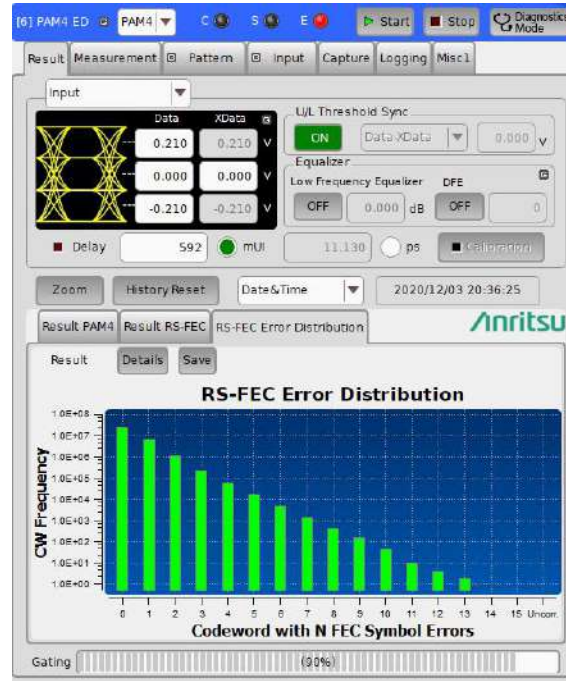

Uncorrectable Errors

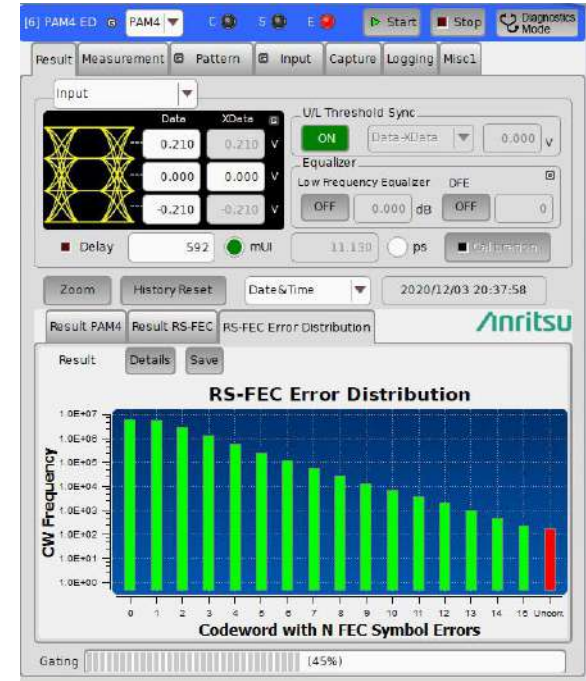

Stress Injection

Decoding Function

Supports Gray decode function

Decodes input data and measures FEC Symbol Errors

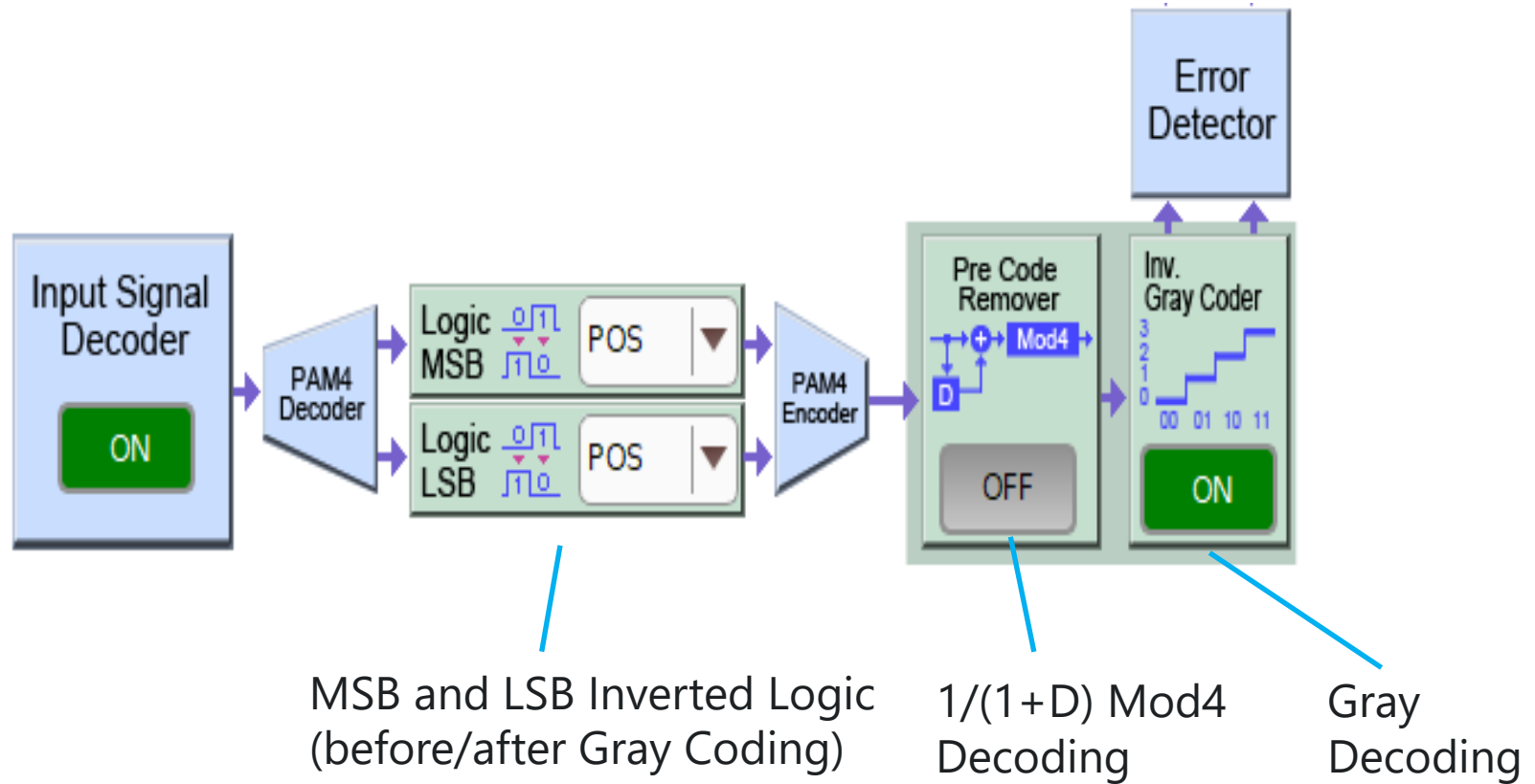

FEC Symbol Capture Function (1/2)

- High input sensitivity performance of 36 mV EH at 53 Gbaud plus FEC Symbol Capture function for Pre-FEC jitter tolerance evaluation and analysis of FEC uncorrectable errors
- FEC Symbol Error detection for IEEE802.3-defined RS-FEC Codeword length and FEC Symbol length standards
- Input signal capture at timing exceeding settable FEC Symbol error threshold (1 to 32 per step), and Input Pattern Analysis function for causes of errors exceeding the threshold

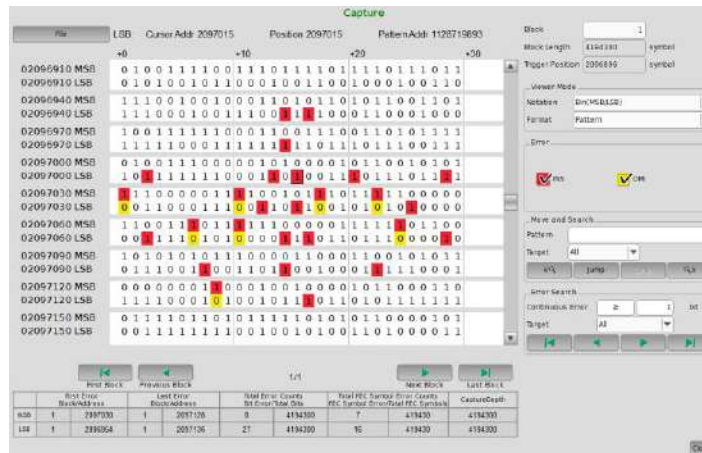
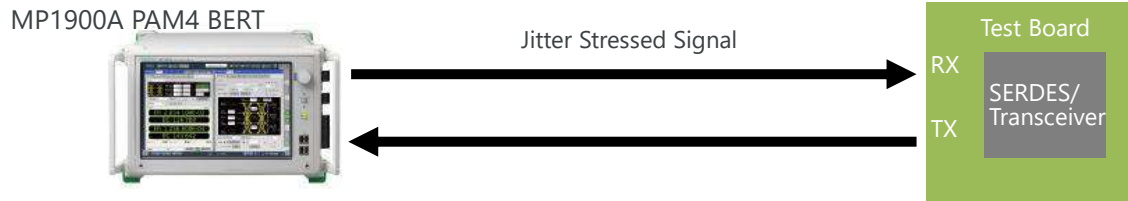

Capturing Detected FEC Symbols Errors

FEC Symbol Capture Function (2/2)

Detect FEC Symbol Errors in Codeword.

The input data is captured when the number of FEC symbol errors exceeds the threshold setting. The causes of FEC-uncorrectable errors can be analyzed from the captured data.

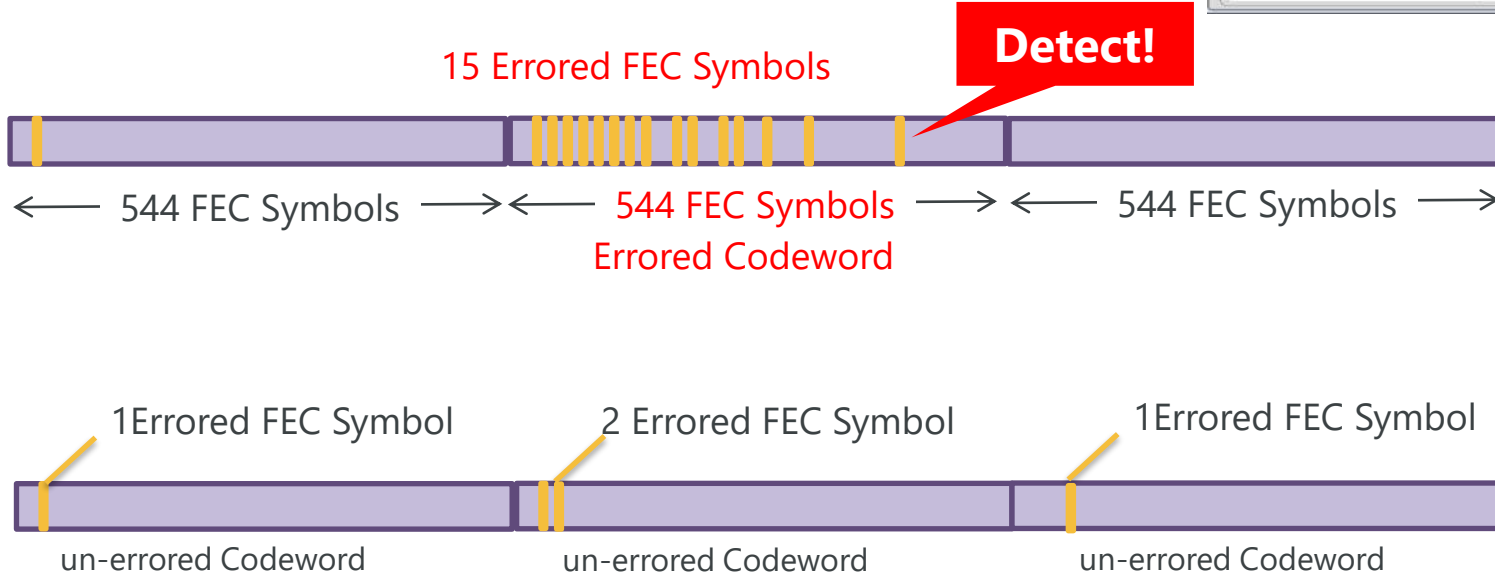
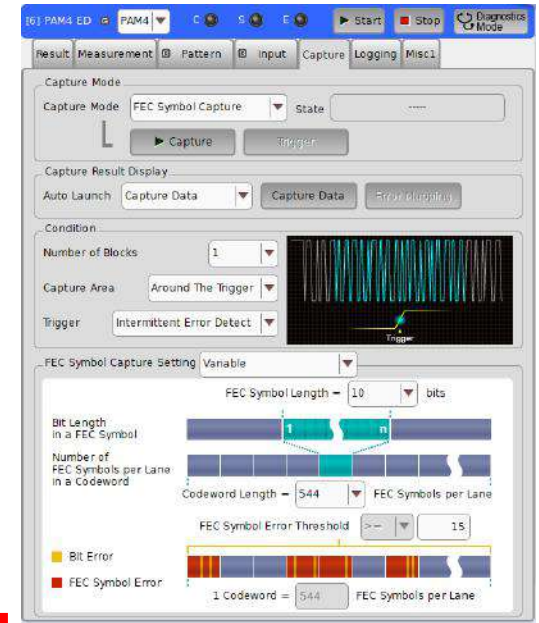

Bathtub Jitter Analysis Function

The input signal jitter and phase margin can be measured automatically using the Bathtub function.

The wideband and high-sensitivity PAM4 ED helps more accurate measurement of DUT performance.

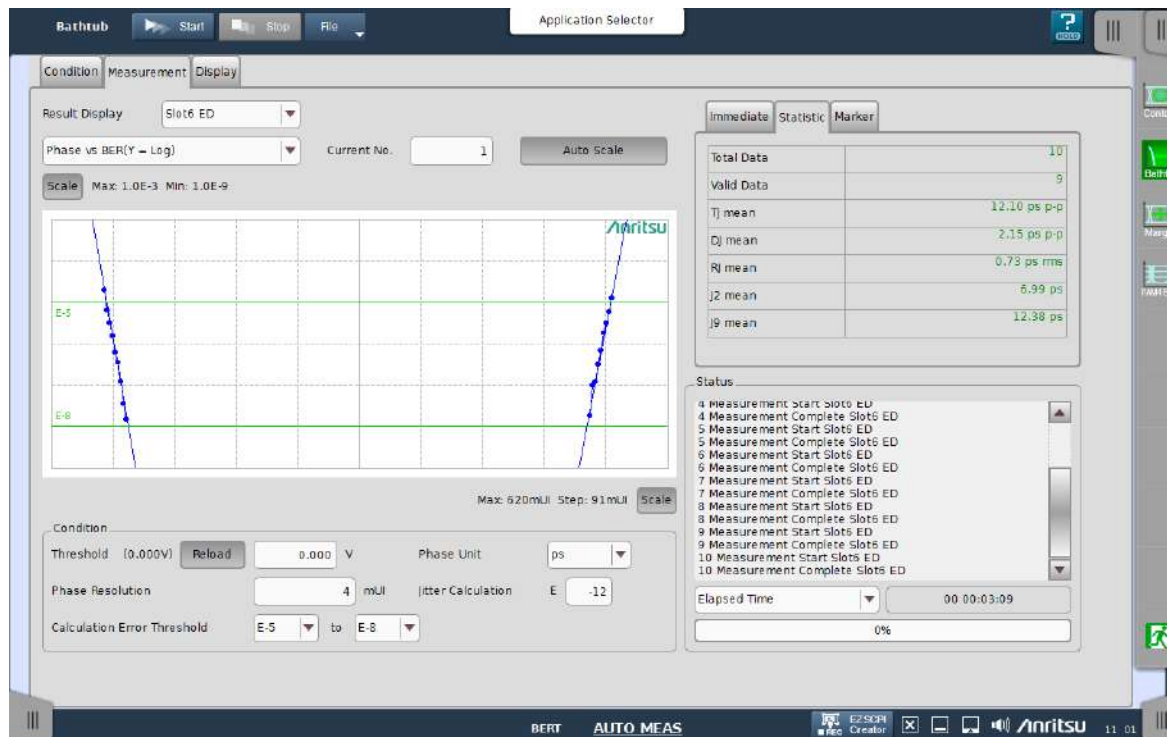

Example of PAM4 Signal Bathtub Measurement

Error Analysis Function (1/2)

Useful measurement of both symbol errors (MU196040B-041) and bit errors for specifying error causes by comparing both measurement results
Press [Details] for more detailed analysis by confirming results for 12 error types.

Input

Upper Eye Threshold 0.165

Middle Eye Threshold 0.000

Lower Eye Threshold -0.165

U/L Threshold Sync ON

Delay 0 mUI 0.000 ps Calibration

2018/10/20 18:33:56

| | Symbol | Bit |
|-----------------------|---------------|------------------------|
| ER | 2.834 100E-02 | 1.256 800E-04 |
| EC | 116 708 | 143 642 |
| %EFI | 50.000 000 | |
| EI | 10 | |
| Clock Loss | 123 | |
| Sync Loss | 234 | |
| Error | | |
| Clock Count | 1.079 100E+09 | Frequency(kHz) 32 000 |
| Middle Data Threshold | | Middle XData Threshold |

Details

PAM4 bit-error measurement results

Separate error-rate measurements for MSB and LSB

Simultaneous measurement of 12 error types

| | Total | INS | OMI |
|--------|---------------|---------------|---------------|
| MSB ER | 7.685 700E-05 | 1.857 800E-04 | 6.017 900E-07 |
| EC | 82 942 | 82 560 | 382 |
| LSB ER | 9.531 300E-04 | 2.564 100E-05 | 1.499 000E-03 |
| EC | 60 700 | 605 | 60 095 |

| | Level 0 | Level 1 | Level 2 | Level 3 | Symbol |
|------------|---------------|---------------|---------------|---------------|---------------|
| ER | | | | | |
| to Level 3 | 5 768 | 786 | 435 | | |
| to Level 2 | 6 445 | 9 467 | | 6 447 | |
| EC | | | | | |
| to Level 1 | 345 | | 76 008 | 778 | |
| to Level 0 | | 8 987 | 786 | 456 | |
| Total | 12 558 | 19 240 | 77 229 | 7 681 | 116 708 |
| ER Total | 1.239 800E-02 | 1.887 100E-02 | 7.167 000E-02 | 7.620 700E-03 | 2.834 100E-02 |

Clock Loss 123 Sync Loss 234 Error

Error Analysis Function (2/2)

The Diagnostics Mode is useful for troubleshooting logic errors, such as inverted logic and MSB/LSB bit skew, etc. When these types of logic errors prevent synchronization, the cause can be determined using the separate MSB and LSB error results and the bit skew result between MSB and LSB.

[6] PAM4 ED PAM4 C S E Start Stop **Diagnostics Mode**

Result Measurement Pattern Input Capture Misc1

Input

| | Data | XData | U/L Threshold Sync |
|----------------------|--------|-------|--------------------|
| Upper Eye Threshold | 0.165 | --- | ON |
| Middle Eye Threshold | 0.000 | --- | Data-XData |
| Lower Eye Threshold | -0.165 | --- | --- |

Delay 0 mUI 0.000 ps Calibration

History Reset Date&Time 2018/10/20 18:42:32

| | Total | INS | OMI | Sync Loss |
|--------------|---------------|---------------|---------------|-----------|
| MSB ER | 7.685 700E-05 | 1.857 800E-04 | 6.017 900E-07 | 345 |
| MSB EC | 82 942 | 82 560 | 382 | |
| LSB ER | 9.531 300E-04 | 2.564 100E-05 | 1.499 000E-03 | 456 |
| LSB EC | 60 700 | 605 | 60 095 | |
| MSB + LSB ER | 1.256 800E-04 | 1.777 000E-04 | 8.961 400E-05 | 777 |
| MSB + LSB EC | 143 642 | 83 165 | 60 477 | |

Clock Loss 123

Frequency(kHz) 32 000 MSB/LSB Diff -10

| | MSB | LSB | MSB + LSB |
|-------------|---------------|---------------|---------------|
| Clock Count | 1.079 100E+09 | 6.368 400E+07 | 1.142 800E+09 |

Middle Data Threshold --- V Middle XData Threshold --- V

Diagnostics Mode button

Separate MSB and LSB error results

MSB/LSB bit skew detection

PAM4 Symbol Capture Function

Capture function supports identification of PAM4 error symbols and cuts verification time.

Can specify error symbol position and level change of captured signal

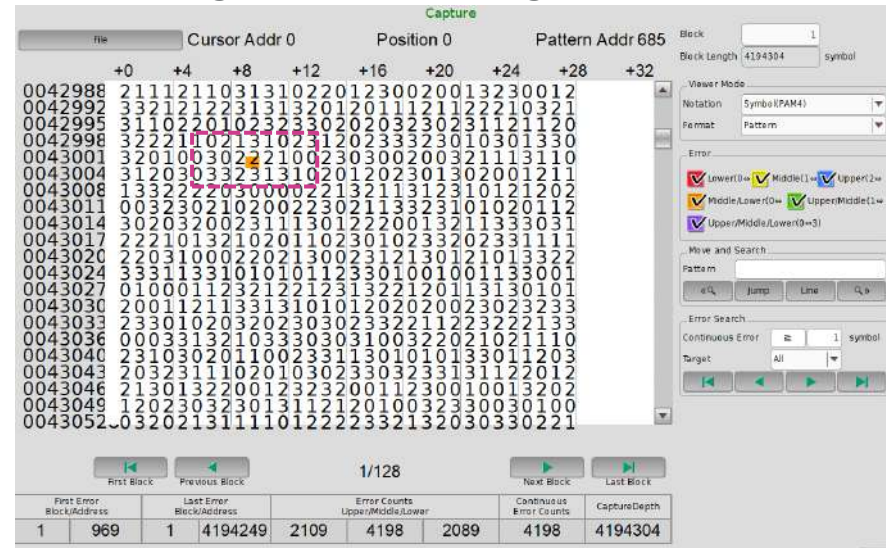
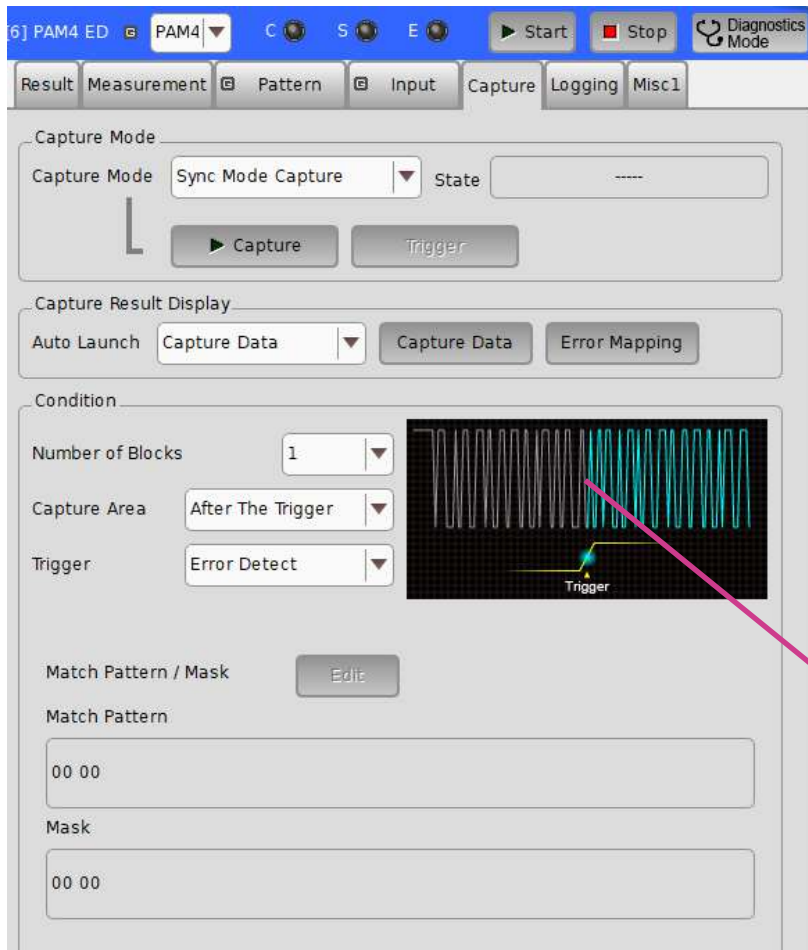

Start capturing inputting symbols using Error detection, Match pattern, or External trigger.

Measurement Result Logging Function

Periodic saving of BER/SER, etc., measurement results can evaluate changes and stability of DUT time-dependent performance.

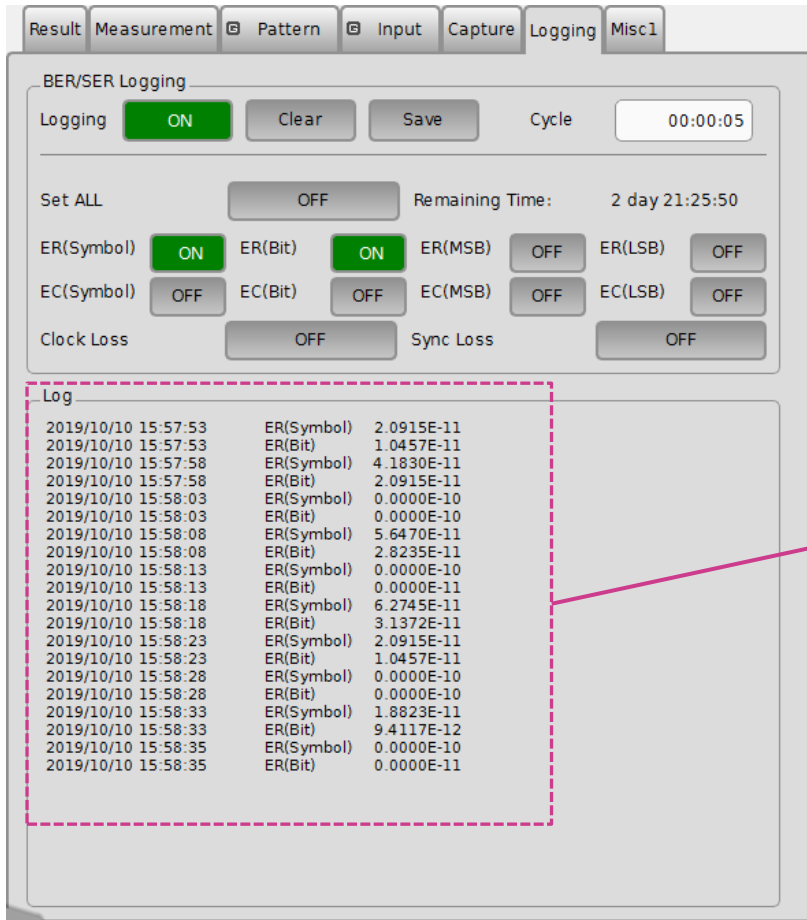

Sets measurement cycle and starts logging
Saves results to file

Measurement item selection

Times-periodically saved measurement results

Appendix

Typical Configuration of 64 G PPG/58 G ED

| Model | Name | Option | Qty | Remark |
|-----------|----------------------------|------------------------------|-----|----------------------|
| MP1900A | Signal Quality Analyzer-R | - | 1 | |
| MU181000B | 12.5GHz 4 port Synthesizer | - | 1 | |
| MU181500B | Jitter Modulation Source | - | 1 | For jitter injection |
| MU196020A | PAM4 PPG | 002, 011, 040, 042 | 1 | |
| MU196040B | PAM4 ED | 002, 011, 021, 023, 041, 042 | 1 | |

Software for jitter tolerance test

| Model | Name |
|-----------------|-------------------------|
| MX183000A-PL001 | Jitter Tolerance Test |
| MX183000A-PL031 | DUT Error Counts Import |

Optional parts

| Model | Name |
|--------|---|
| J1789A | Electrical Length Specified cable (0.4m, V connector) |
| J1790A | Electrical Length Specified cable (0.8m, V connector) |
| J1800A | ISI Board V |
| J1793A | Pick OFF Tee (V) |

64 G PPG/58 G ED Module Option

| Model | Name |
|---------------|------------------------------|
| MU196020A | PAM4 PPG |
| MU196020A-001 | 32G baud |
| MU196020A-002 | 58G baud |
| MU196020A-003 | 64G baud |
| MU196020A-011 | 4Tap Emphasis |
| MU196020A-030 | Data Delay |
| MU196020A-040 | Adjustable ISI |
| MU196020A-042 | FEC Pattern Generation |
| MU196020A-050 | Intel-Module Synchronization |

| Model | Name |
|---------------|--|
| MU196040B | PAM4 ED |
| MU196040B-001 | 32G baud |
| MU196040B-002 | 58G baud (max. 64.2Gbit/s NRZ/58.2Gbaud PAM4) |
| MU196040B-011 | Equalizer |
| MU196040B-021 | 29G Clock Recovery (2.4 G to 29 Gbaud) |
| MU196040B-022 | 32G Clock Recovery (2.4 G to 32.1 Gbaud) |
| MU196040B-023 | 58G Clock Recovery Extension (51 G to 58 Gbaud) |
| MU196040B-041 | SER Measurement |
| MU196040B-042 | Jitter Analysis |

PAM4 PPG MU196020A Specifications

| Item | Specification | Remarks |
|-----------------------------------|--|-------------------|
| Operation Rate | 2.4 Gbaud to 32.1/58.2/64.2 Gbaud | Option selection |
| Signal format | NRZ, PAM4 | |
| Number of Outputs | 2 (Data, xData) | |
| Output Amplitude | 70 mVp-p to 800 mVp-p (Single-end) 140 mVp-p to 1600 mVp-p (Differential) | |
| Offset | -2 V to +3.3 V | |
| Emphasis | 4 Tap, -20 to +20 dB | Option |
| Channel Emulator | Generates waveform with insertion loss and simulates waveform with corrected insertion loss Set by loading S-Parameter file (S2P, S4P) | Option |
| ISI | Simulates ISI generation waveform Set using loss (-8.00 to 8.00 dB) at CEI-specified Nyquist frequency Used in combination with channel board, such as J1800A/J1758A (optional accessories parts), or Noise Module MU195050A | Option |
| Independently Variable PAM4 3 Eye | 20% to 50% (PAM4 Amplitude 0/3 level = 100%) | |
| PAM4 Pattern | SSPRQ, PRBS13Q, PRBS31Q, RS-FEC, etc. | Option for RS-FEC |
| PAM4 Pattern Error Addition | MSB Error, LSB Error, LSB&MSB Error, RS-FEC Symbol Error | Option for RS-FEC |
| Tr/Tf (20% to 80%) | 8.5 ps (typ., NRZ) | |
| Random Jitter | 170 fs rms (typ., NRZ) | |
| I/O Connector | V (f) | |
| Jitter Addition Function | SJ, RJ, BUJ, SSC (with MU181500B) | |
| Noise Addition Function | CMI, DMI, White Noise (with MU195050A (32.1G max.) and J1792A) | |

PAM4 ED MU196040B Specifications

| Item | Specification | Remarks |
|------------------------------|---|------------------------------|
| Baud rate | 2.4 Gbaud to 32.1 / 64.2 Gbaud (NRZ) 2.4 Gbaud to 32.1 / 58.2 Gbaud (PAM4) | Select upper limit as option |
| Input Signal format | NRZ, PAM4 | |
| Number of Inputs | 2 (Data, xData) | |
| Input Amplitude | 1.0 Vp-p (max.) | |
| Input Sensitivity | 36 mV (typ. at 53.125 G), 23 mV (typ. at 26.5625 G) (Eye Height of each PAM4 Eye) | |
| Stressed Margin | BER < 1 E-8 (When inputting minimum eye signal defined in CEI-112G-VSR) | |
| Analog Band | >40 GHz (nominal) | |
| Clock Recovery | 2.4 Gbaud to 29 Gbaud or 2.4 Gbaud to 32.1 Gbaud | Option |
| Operation Range | 51 Gbaud to 58.2 Gbaud Extension | |
| Equalizer | DFE (1.4 dB) + Low-frequency-Equalizer (2 dB) | Option |
| BER/SER | Total BER, MSB/LSB BER, SER | Option for SER |
| Measurement | Logging, Capture (8 M bits/4 M PAM4 symbols) | |
| FEC Symbol Error measurement | Uncorrectable Codeword Error, FEC Symbol Error, RS-FEC Error Distribution | Option |
| Patterns | PRBS, Data (max. 268 Mbit (symbol)), PAM4 Pattern (PRBS13Q, PRBS31Q, SSPRQ, QPRBS13-CEI, QPRBS31-CEI), Gray Code/PAM4 Pre-Code, RS-FEC pattern | Option for RS-FEC pattern |
| Connector | V (f) | |

Typical 100G x 4 Multichannel Configuration

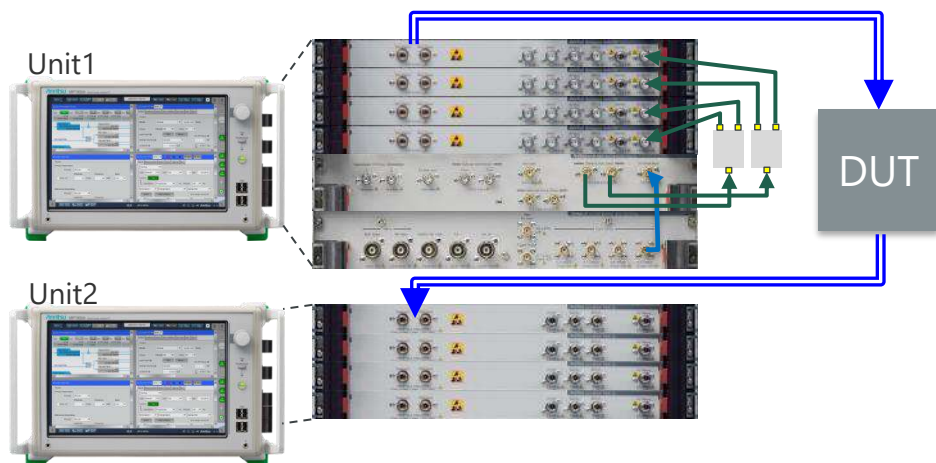

Unit1

| Model | Name | Qty |
|-----------|--|-----|
| MP1900A | Signal Quality Analyzer-R | 1 |
| MU181000B | 12.5GHz 4 port Synthesizer | 1 |
| MU181500B | Jitter Modulation Source | 1 |
| MU196020A | PAM4 PPG (Opt. 002,011, 030, 040, 042, 050) | 4 |
| J1748A | Power Splitter (1.5G-18GHz) | 2 |
| J1728A | Electrical Length Specified Coaxial Cable(0.4m, K) | 6 |

Unit2

| Model | Name | Qty |
|-----------|---|-----|
| MP1900A | Signal Quality Analyzer-R | 1 |
| MU196040B | PAM4 ED (Opt. 002, 011, 021, 023, 041, 042) | 4 |

Test cable

| Model | Name | Qty |
|------------------|---|-----|
| J1789A or J1790A | Electrical Length Specified cable 0.4 m or 0.8 m (V connector) | 16 |

