



CHIMERA

RELEASE 1

5-speed 2-port network impairment emulator

Chimera can emulate network impairments at five Ethernet network speeds: 100GE, 50GE, 40GE, 25GE and 10GE. This unique flexibility is provided via two physical transceiver cages, both supporting QSFP28 and QSFP+ transceivers.

The result is a versatile solution that provides consistent, accurate, well-defined and repeatable impairments to the traffic between DUTs – in the lab. This is ideal for benchmarking, stress/negative, “what-if” and regression testing of network infrastructure and Ethernet equipment capable of supporting 100GE such as switches, routers, NICs and fronthaul/ backhaul platforms.

- | TOP FEATURES |
|---|
| • 5-speed flexibility: 100GE, 50GE, 40GE, 25GE and 10GE |
| • 2-port capacity |
| • Integration with Valkyrie traffic generator |
| • Price/performance |
| • Ease of use |
| • Free software (incl. ValkyrieManager and XenaScripting) |
| • Free tech support product lifetime |



Chimera is available as standalone ChimeraCompact and as a 2-slot test module for the ValkyrieBay

PORT LEVEL FEATURES	
Interface category	QSFP28 • 100G, 50G, 40G*, 25GE and 10G* Ethernet QSFP+ • 40G, 10G Ethernet * Depending on transceiver capabilities
Total number of test ports (software configurable)	2x100G, 2x50G, 2x40G, 2x25G, and 2x10G Ethernet (planned 2x100G, 4x50G, 2x40G, 4x25G, and 4x10G Ethernet)
Interface options	Each cage <ul style="list-style-type: none"> • 1 x 100GBASE-SR4/LR4/CR4, or 802.3bj standard Consortium** • 2 x 50GBASE-SR2/LR2/CR2, or 802.3ba • 1 x 40GBASE-SR4/LR4/CR4, or 802.3by/Consortium** • 4 x 25GBASE-SR/LR/CR, or 802.3ae • 4 x 10GBASE-SR/LR/CR Actual interface options depend on the capabilities of the inserted transceiver. Both cages must run with the same base interface configuration (e.g. 2 x 50G). ** As defined by 25/50 GigabitEthernet Consortium
Auto Negotiation and Link Training	IEEE 802.3 Clause 73, Auto-negotiation IEEE 802.3 Clause 72, Link training
Forward Error Correction (FEC)	RS-FEC (Reed Solomon) FEC, IEEE 802.3 Clause 91 (100GE) RS-FEC (Reed Solomon) FEC, IEEE 802.3 Clause 108 (25GE) RS-FEC (Reed Solomon) FEC, 25/50G Ethernet Consortium (25/50GE)
Number of transceiver module cages	2 x QSFP28/QSFP+
Port statistics	Link state, FCS errors, pause frames, ARP/PING, error injections, training packet
Adjustable Inter Frame Gap (IFG)	Configurable from 16 to 56 bytes, default is 20B (12B IFG + 8B preamble)
Transmit line rate adjustment	From -400 to 400 ppm in steps of 0.001 ppm (shared across all ports)
Field upgradeable	System is fully field upgradeable to product releases (FPGA images and software)
Tx disable	Enable/disable of optical laser or copper link
Oscillator characteristics	<ul style="list-style-type: none"> • Initial Accuracy is 3 ppm • Frequency drift over 1st year: +/- 3 ppm (over 15 years: +/- 15 ppm) • Temperature Stability: +/- 20 ppm (Total Stability is +/- 35 ppm)

NOTE: Features in green will be made available in 3 future releases.



100/50/40/25GE FRAMED PRBS AND PCS LAYERS

Payload Test pattern	PRBS 2 ³¹
Error Injection	Manual single shot bit-errors or bursts, automatic continuous error injection
Frame size and header	Fixed size from 56 to 9200 bytes, any layer 2/3/4 frame header
Alarms	Pattern loss, bit-error rate threshold
Error analysis	bit-errors: seconds, count, rate per physical lane
PCS virtual lane configuration	User-defined skew insertion per Tx virtual lane, and user defined virtual lane to SerDes mapping for testing of the Rx PCS virtual lane re-order function.
PCS virtual lane statistics	Relative virtual lane skew measurement (up to 2048 bits), sync header and PCS lane marker error counters, indicators for loss of sync header and lane marker, BIP8 errors

FLOWS

Number of flows per port	Up to 8 including default flow
Flow filter definition	MAC Source and Destination Address VLAN Tag (C-Tag and S-Tag) MPLS Label IPv4 Source and Destination Address IPv4 DSCP/TOS IPv6 Source and Destination Address UDP/TCP port numbers Up to 6 consecutive bytes in the packet Xena Test Payload ID (TID)
Multiflow output control	FIFO Round Robin Flow Priority Strict Priority (VLAN priority, MPLS priority, IP (DSCP/TOS (IPv4) or Traffic Class (IPv6)))
Libraries	Libraries of own impairments MEF-18 ITU-T G.8261 G.1050/TIA-921

IMPAIRMENT PER FLOW

General	Impairments can be changed dynamically
Packet Manipulation	Packet drop (Random, Burst, Periodic, BER, Gilbert-Elliott) Packet drop up to 100%. Step size: 0.0001%. Duplication Mis-ordering Corruption (Ethernet Frame FCS, IP header Check Sum error, UDP Check Sum error, TCP Check Sum error)
Latency / jitter	Constant Uniform Exponential Accumulate & Burst Jitter (Gaussian) Max latency 160000 µsec (100GE wire-speed) Step size 1 ns, accuracy: +/- 150 ns
Bandwidth Control	Policing Shaping

CAPTURE & FLOW DISCOVERY

Capture criteria	TBD
Capture start/stop triggers	TBD
Capture limit per packet	TBD
Wire-speed capture buffer per port	TBD
Flow discovery	Define flow filters based on captured traffic

ADVANCED PHY FEATURES

Transmit Equalization Controls	<ul style="list-style-type: none"> Tx Transmit Equalization Controls Pre-emphasis Tx Attenuation Tx Post-emphasis Signal Integrity Analysis Rx Optional Auto-Tune of PHY 50 & 25Gbps Rx SerDes
--------------------------------	--



How Chimera processes incoming traffic:

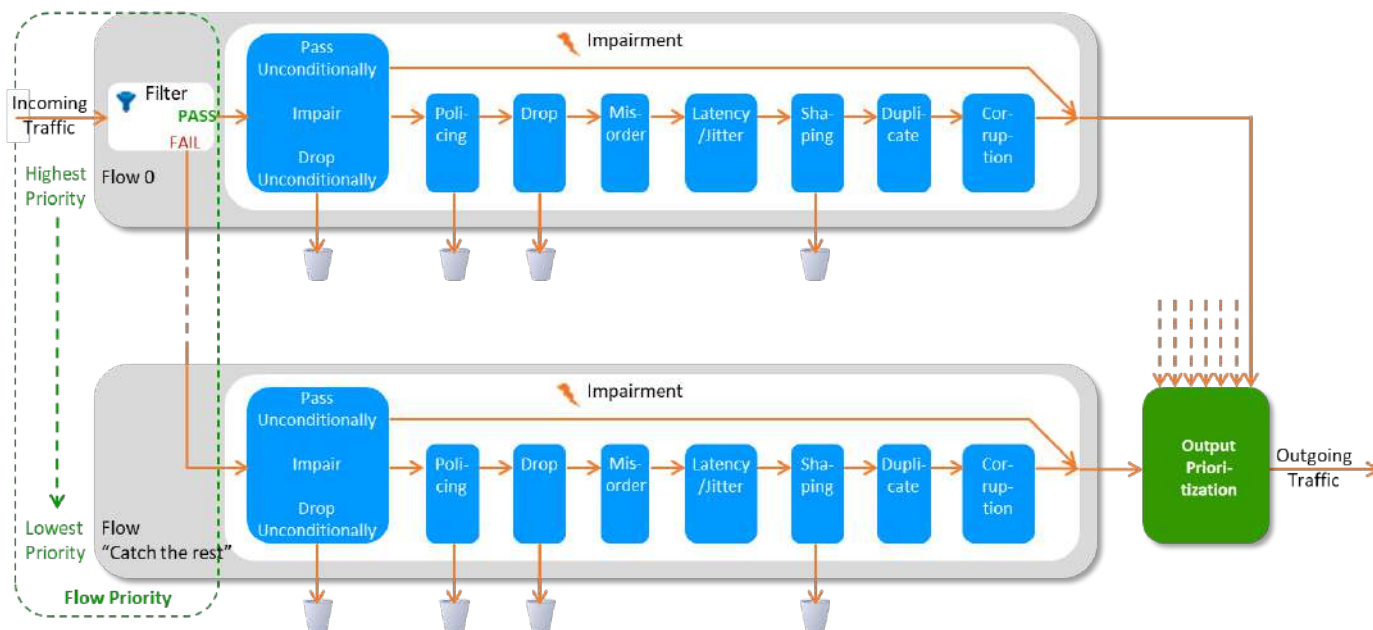

One module - multiple options

Chimera has 2 transceiver cages. The type of transceiver used determines the speeds and number of ports available. The port number / speed configuration must be the same for both cages and this is defined using ValkyrieManager, Xena's traffic generation and analysis software.

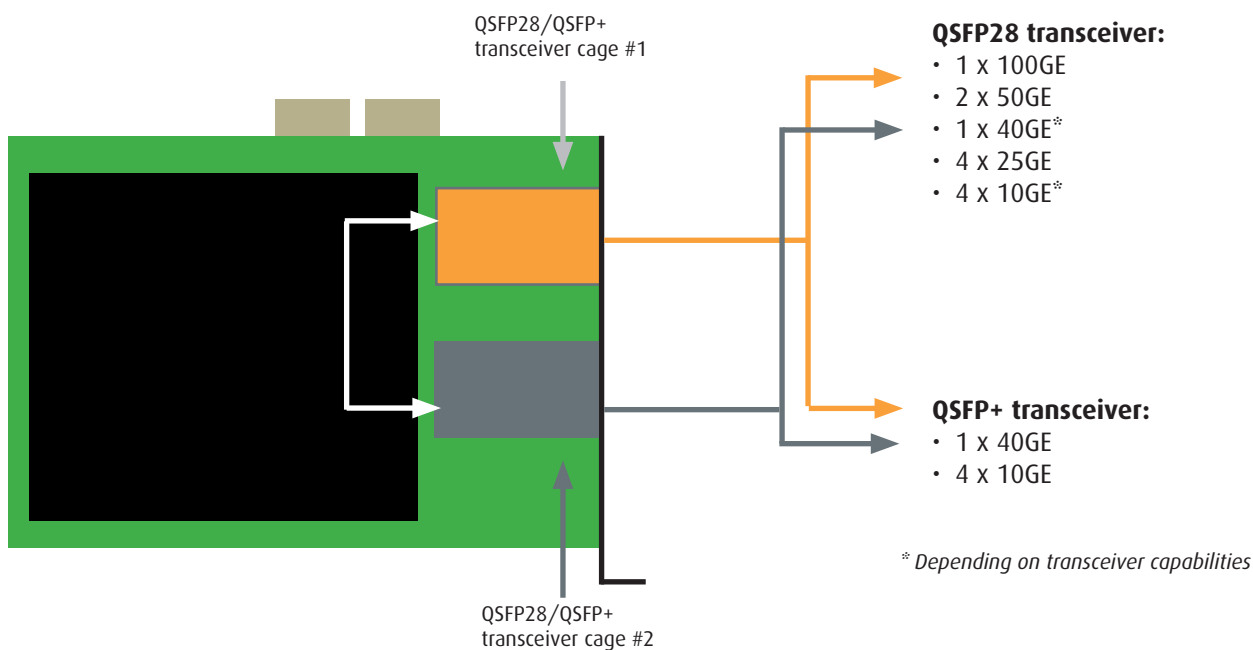

SPECIFICATIONS

Dimensions

1U ChimeraCompact

- W: 19" (48.26 cm)
- H: 1.75" (4.45 cm)
- D: 9.8" (25 cm)
- Weight: 10 lbs (4.5 kg)

Environmental

- Operating Temperature: 10 to 35° C
- Storage Temperature: -40 to 70° C
- Humidity: 8% to 90% non-condensing

Power

- AC Voltage: 100-240V
- Frequency: 50-60Hz
- Max. Power: 90W (ValkyrieCompact) / 120W (ValkyrieBay)
- Max. Current: 0.8A with 120V supply, and 0.4A with 240V supply

Max. Noise

- ValkyrieCompact: 49 dBa
- ValkyrieBay: 58.5 dBa

Regulatory

- FCC (US), CE (Europe)

