

The VIAVI logo is displayed in a white, bold, sans-serif font. The letters are spaced out, with the 'V' and 'I' being significantly larger than the 'A' and 'V'.

VIAVI Solutions

Brochure

# VIAVI

## TM500 O-RU Tester

Conformance, Performance  
and Interoperability Testing  
of the O-RAN Radio Unit

Part of the VIAVI  
O-RAN Test Suite

Allowing customers to ensure conformance, interoperability and performance test

## Open RAN Testing with VIAVI

With the greater complexities of testing disaggregated networks, it is vital to adopt the right test strategy and choose scalable tools that can support your overall needs.

Whether your requirements include end-to-end performance testing of a multi-vendor solution with interoperability between those multi-vendor components or whether you require component conformance testing with the ability to test the interoperability and performance of both individual and combined components, VIAVI has the tools to support you.

With a larger range of network components it is vital to select scalable test tools that can support you, not just for conformance testing but can be used for full closed loop signalling to support a range of real-world test scenarios including large numbers of UEs, mobility, mixed traffic types and maximum data rates.

### Testing the O-RAN Radio Unit (O-RU) with the TM500

The VIAVI TM500 O-RU Tester covers a wide range of test capabilities, allowing customers to ensure conformance, inter-operability and performance testing including real-time generation of the O-RAN Control/User/Synchronization/Management plane messaging for the I/Q data stream. The TM500 O-RU Tester supports interoperability validation for different vendor O-RUs, addressing key challenges seen with testing within the O-RAN test framework.



Conformance, interoperability and performance testing



Fully stateful testing over the O-RAN Open Fronthaul interface



Extensions to characterize and optimize performance of 5G NR

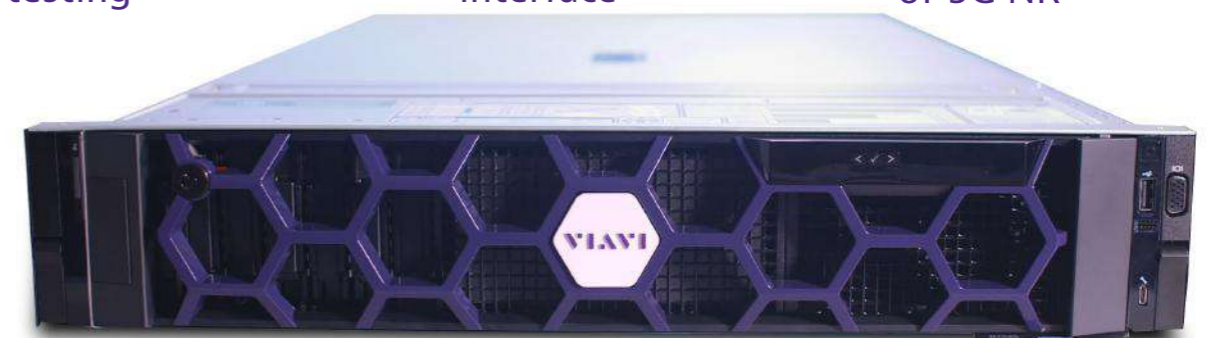

# Conformance, Performance and Interoperability

Conformance testing involves performing specific tests according to O-RAN specifications:

Example: Conformance testing of the C,U,S and M planes according to Working Group 4 O-RAN standards

Although conformance testing is important, testing it alone is not enough. Infrastructure might meet certain standards when elements are tested independently, but when it comes to interoperability, you need to make sure you can guarantee what you are testing will function as part of an end-to-end architecture, alongside other elements.

## Transport and Application Layer Performance

The O-RU is a network entity, it is therefore necessary to ensure that performance is acceptable at both the transport and application layers e.g. synchronization and timing issues at the O-RAN fronthaul layer should not affect any applications, especially latency-sensitive applications such as voice over NR.

## Functionality Requirements

We understand that each of our customers will have different requirements in terms of the functionality of the O-RU e.g. different frequency bands, MIMO schemes etc. Infrastructure must be tested to ensure interoperability with these requirements. This ensures for instance that the M-plane is able to cope with different vendor requirements, ultimately facilitating end-to-end testing without any performance compromises.

## Scalable Test Platform

With a greater scope of components in an Open RAN environment, it is important to select scalable test tools that can support not just conformance testing but can be upgraded to do performance tests at the higher layers e.g. the 5G stack. This will support a range of real-world test scenarios including large number of UEs, mobility, mixed traffic types and maximum data rates. The TM500 O-RU Tester has a scalable architecture, making it both a stepping stone to; and complementary to full end-to-end testing and works seamlessly with other VIAVI tools in the VIAVI 5G O-RAN portfolio.

### Beyond Conformance Testing

Think of it like testing white goods to check that they conform to industry standards. You do the necessary checks, the product passes, and you stamp it with a 'CE' mark. All good? Not quite. You then try and switch it on and although it meets the required specs, the product doesn't actually work.

Conformance testing is important, NEMS and Operators must go beyond that

Conformance testing with the ability to validate the interoperability and performance of both individual and combined components

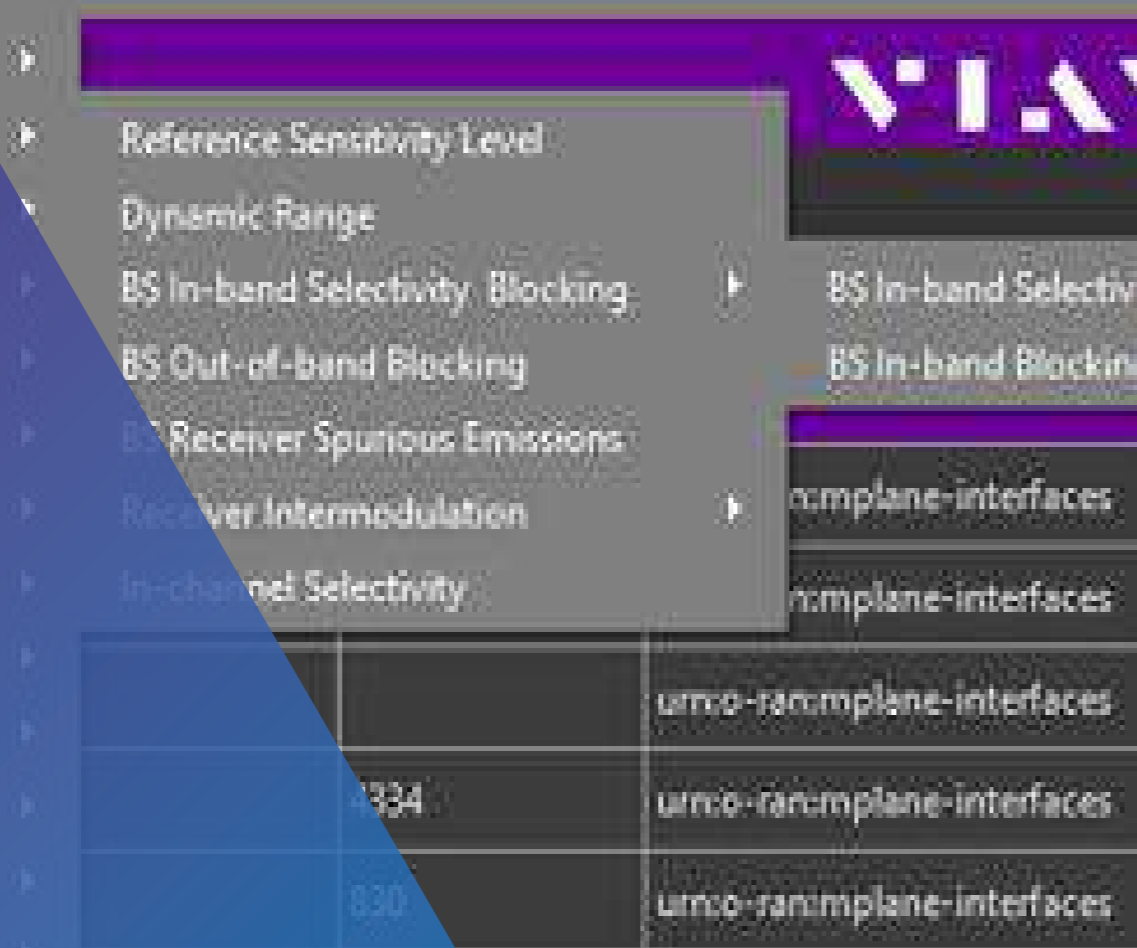

## How the TM500 O-RU Tester Works

The TM500 O-RU Tester implements the O-RAN Distributed Unit (O-DU) side of the M-plane and C/U-plane functionality necessary to configure the interface with the O-RAN Radio Unit (O-RU) under test and exchange of I/Q data over the U-plane. The solution provides S-plane PTP and SyncE Grandmaster capability as well as being able to operate in PTP client mode to allow synchronization with an external PTP Grandmaster.

The TM500 O-RU Tester NETCONF client supports stateful M-plane. The O-DU cycles through typical M-plane procedures and establishes a link with the O-RU. The O-DU emulator C/U-plane engine, generates real-time eCPRI packets from downlink signal generated by the Vector Signal Generator (VSG). eCPRI packets are transported to O-RU via the Open Fronthaul interface. Vector Signal Explorer (VSE) software and a Vector Signal Analyzer (VSA) support the analysis of downlink signal from the O-RUs transceiver port.

The O-RU receives uplink signal via the O-RU Rx port from VSG. Uplink U-plane eCPRI packets are transported to the O-DU emulator via the Open Fronthaul interface in response to the Uplink focused C-plane packets received by O-RU. Frequency domain uplink signal is analyzed using VSE software. The TM500 O-RU Test Manager Application (TMA) follows the philosophy of single point of control where it enables the user to configure, manage, analyze and generate test case reports all from the same application.

### Key Features

- NETCONF Client to support Start-Up and get/edit configuration of M-plane attributes in the O-RU under test
- O-RAN C/U-plane functionality to exchange I/Q data over Lower Layer Split 7-2x interface
- Real time C/U-plane eCPRI packets generation
- Embedded protocol analyzer for OFH traffic analysis
- C/U-plane messaging support with eCPRI over Ethernet
- PTP/SyncE Grandmaster + PTP Client for Synchronization with external PTP Master
- OFH interface connectivity monitoring
- Wide range of synchronization topologies
- Multiple options for stimulus waveform generation

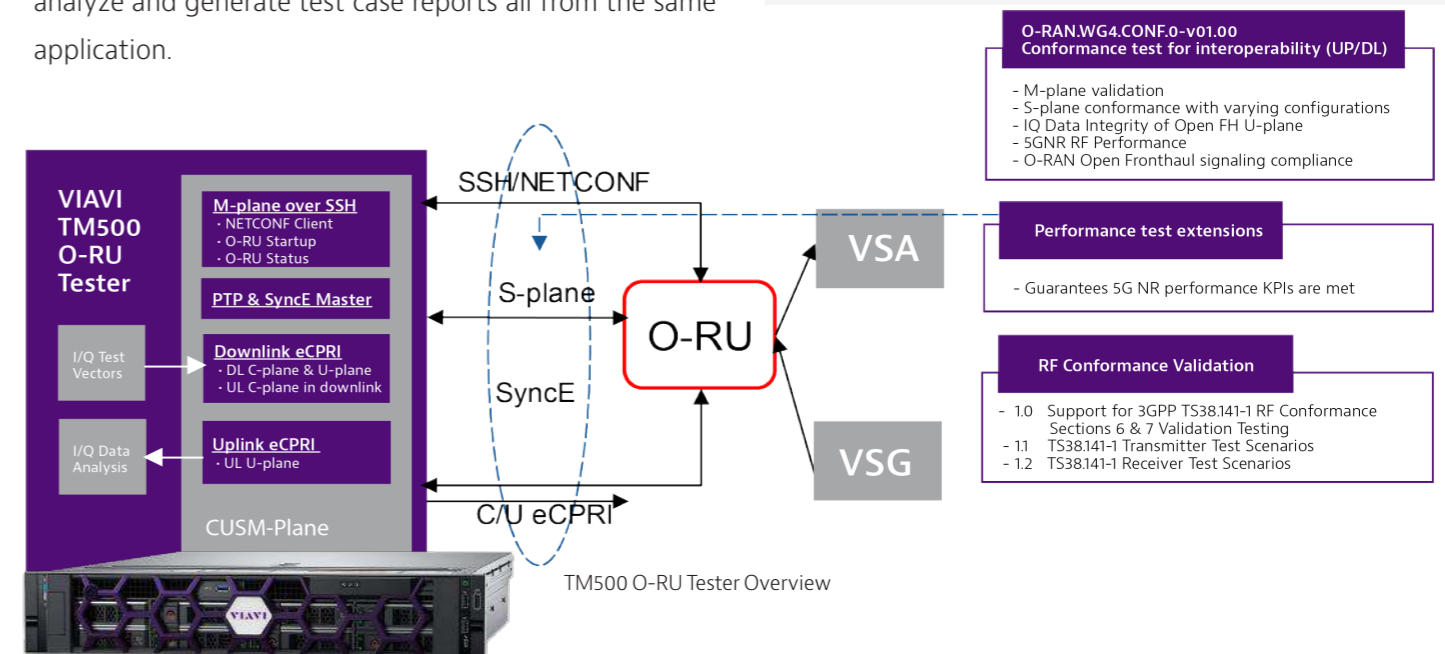

# TM500 O-RU Test Manager Application (TMA)

## M-Plane Validation

- Transport Connectivity
- M-plane Start-up of O-RU
- NETCONF Subscriptions
- Performance Measurements
- M-plane Connection Supervision
- O-RU Information Retrieval and Configurability

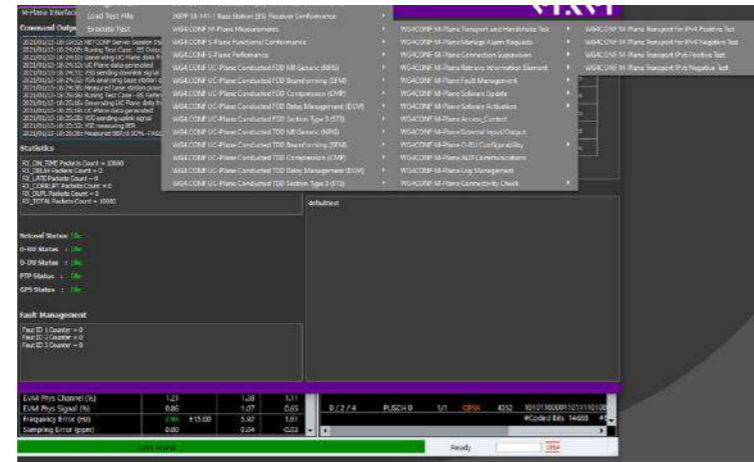

This is the screen grab of M-plane measurements conformance test tree

Test cases are ordered to mirror the specification document

TM500 O-RU Test Manager Application follows the philosophy of single point of control where it enables the user to configure, manage, analyze and generate test case reports all from the same application.

## Validation of Open Fronthaul C/U-plane Performance

- U-Plane I/Q Data Integrity
- RF Performance for 5G NR
- Test Case Flexibility

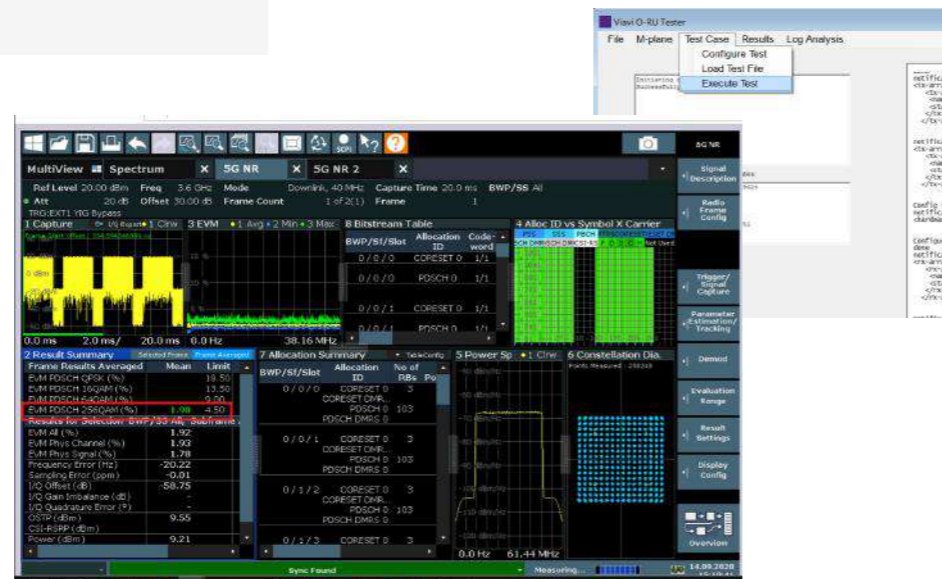

Proven with real vendor O-RUs

Fully stateful real-time solution to test O-RAN CUSM procedures

VIAMI TM500 O-RU Tester extensions

## Validation of Open Fronthaul C/U-Plane Signaling

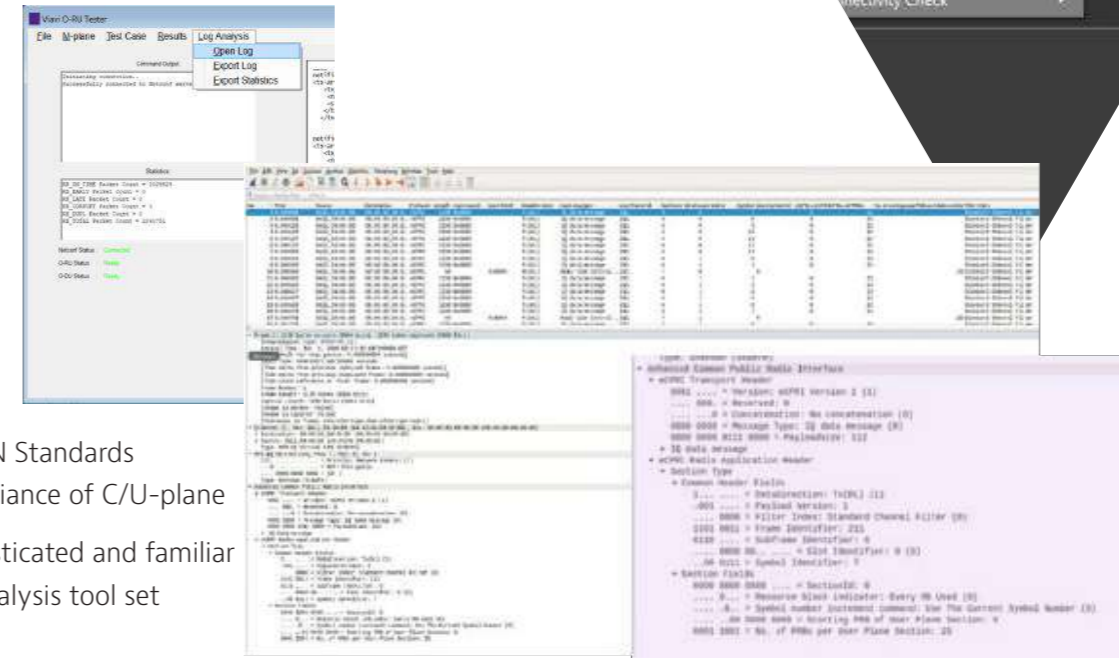

- O-RAN Standards Compliance of C/U-plane
- Sophisticated and familiar log analysis tool set

## O-RU S-Plane Test Use Cases

- Leverage VIAMI extensive experience in ethernet test including transport synchronization
- Provision of PTP Master compliant with ITU-T G.8275.1
- Retrieval of O-RU State Parameters utilizing M-plane
  - Sync State
  - PTP Lock State
  - PTP State
  - PTP Clock-class
  - Sync-E Lock-state
  - Sync-E Quality-level
- Validate UL/DL C/U message timing relative to PTP Master time reference

TM500 O-RU Test cases are configured by:

- 3GPP 38.141 Section 6 and 7 Conformance
- O-RAN Working Group 4 Conformance

## Partnering to deliver the best test capability for our customers

The TM500 O-RU Tester is designed to work with the Rohde & Schwarz SMW200A Vector Signal Generator, FSV3007 Vector Signal Analyzer, and VSE software under a single point of control in TM500 O-RU TMA. The full specifications for the Rohde and Schwarz products can be obtained from the [R&S website](#).

# VIAVI O-RAN Test Suite

Performance; Conformance; Function; Load; System and Multi-vendor Interoperability Testing

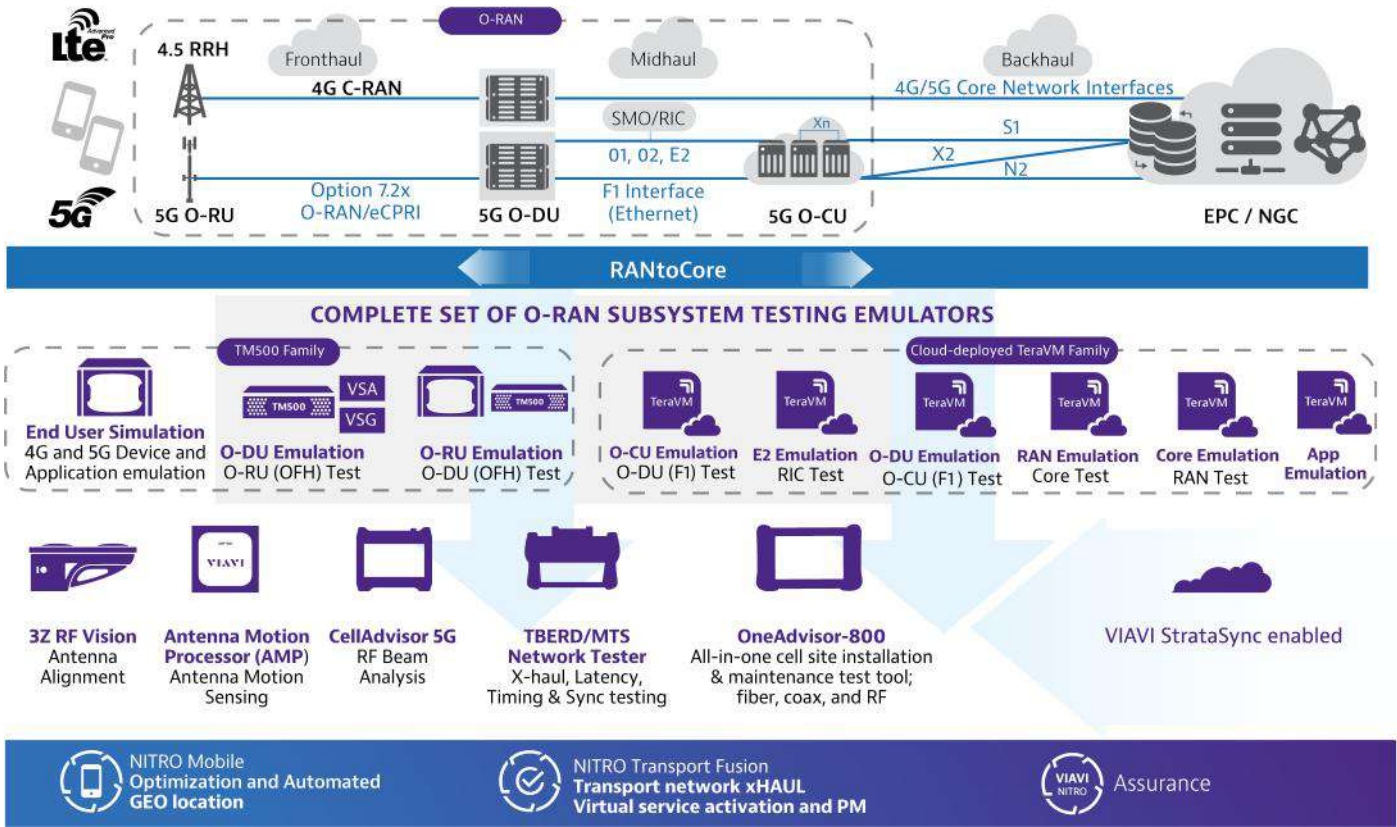

To reach the VIAVI office nearest you, visit [viasolutions.com/contact](https://viasolutions.com/contact)

© 2021 VIAVI Solutions, Inc. Product specifications and descriptions in this document are subject to change without notice. tm500-o-ru-tester-br-wir-nse-ae 30191221 902 0921